

GUIDE TO STANDARDS AND TOLERANCES 2015



FOREWORD

The *Guide to Standards and Tolerances* (the Guide) has been developed for use by builders and building owners as a convenient reference for acceptable standards of workmanship in domestic building construction. It is intended to address areas that are not prescribed under legislation or under a domestic building contract.

Generally, parties to a building contract can agree on the standards they consider appropriate to their building project. Preferably, that agreed scope and standards of work is comprehensively detailed in the contract documents. Where it is not, there is risk of dispute at a later stage.

While the parties can agree on applicable standards, they cannot apply standards lower than those required by building regulation.

The content of this Guide is based on technical standards and industry tolerances that describe (or refer to) what is considered an acceptable standard of finished workmanship in domestic building construction.

It should be understood that this is a guide only and that all other documents prescribing statutory and contractual requirements, relevant to the contract, take precedence over this guide.

Acknowledgement

The *Guide to Standards and Tolerances 2015* was produced by the Victorian Building Authority. All information, diagrams and materials included in this publication, except those expressly indicated as belonging to Standards Australia International Limited (SAIL), are the property of the Victorian Building Authority.

Diagrams and materials included in this publication, the copyright of which is owned by SAIL, have been reproduced by the VBA with the kind permission of the copyright owner and SAI Global Limited (SAI). For the reader's convenience, we have indicated the relevant Australian Standard which references the diagram or materials in question. These are all available for purchase from SAI. For further information, please visit the SAI website at <http://infostore.saiglobal.com/store/>

Disclaimer

The content in this publication is provided for information purposes only. Although the Victorian Building Authority (VBA) believes that all information contained in this document is accurate and reliable as at the date of publication, the information must not be relied on or regarded as legal advice. The VBA provides no warranty about the accuracy, reliability or authenticity of any information or material contained in this publication, and accepts no liability whatsoever for direct or consequential loss or damage to any person in connection with the information or advice (or the use of such information or advice) which is provided in this publication or incorporated by reference. Information is provided on the basis that all persons accessing this publication or any materials referred to in it, do so at their own risk and undertake responsibility for assessing the relevance and accuracy of any and all content.

Copyright

Copyright © Victorian Building Authority.

Copyright in the content and design of this publication including all text, logos, diagrams and images, is owned by the Victorian Building Authority (except to the extent a different copyright owner is expressly identified in the publication).

Except in the limited circumstances set out in the *Copyright Act 1968* (Cth), no part of this publication must be reproduced, copied, adapted, modified, communicated or otherwise used without written permission from the Victorian Building Authority (which may be withheld at the Victorian Building Authority's absolute discretion).

A	Introduction	9
B	Authority of the Guide	10
C	Application of the Guide	11
D	The measurement of time	11
E	The measurement of tolerances	12
F	Inspecting surfaces from a normal viewing position	14
G	Remedial work	15
H	Responsibility to rectify	15
I	Renovations, alterations and extensions	16
J	Recycled materials	16
K	Building maintenance – Care of the building and site after completion	17
L	Australian Standards and other referenced material	17
M	Schedule of References used in this Guide	18
1	SITWORKS (PAVING AND LANDSCAPING)	19
1.01	Cracking in concrete paving	19
1.02	Finish to external concrete paving	20
1.03	Surface drainage	20
2	FOOTINGS, SLABS AND SETTING OUT	21
2.01	Foundation and site drainage – maintenance after occupation	21
2.02	Footings and slabs	22
2.03	Setting out the site	22
2.04	External building dimensions	22
2.05	Measuring internal building dimensions	22
2.06	Building dimensions	22
2.07	Finished floor levels	23
2.08	Levelness of concrete floors	23
2.09	Dimensions of building elements	23
2.10	Cracks in concrete slabs	24
2.11	Finish to concrete slabs	24
2.12	Repairs to exposed concrete slabs	24
3	MASONRY	25
3.01	Masonry types	25
3.02	Damage to masonry walls	25
3.03	Movement; control joints in masonry walls	26
3.04	Masonry construction	26
3.05	Blending and matching of masonry – repair work	30
3.06	Blending and matching of masonry – new work	30
3.07	Masonry facing	31
3.08	Mortar for masonry	31
3.09	Voids and holes in mortar	31
3.10	Cracked masonry unit	31
3.11	Cleaning, mortar smears and stains	31

3.12	Masonry inside garages and similar spaces and under applied finishes	31
3.13	Vertical alignment of perpend joints	31
3.14	Horizontal alignment of bed joints	32
3.15	Base bed joint and base row of masonry	32
3.16	Masonry that overhangs concrete slabs	32
3.17	Damp proof courses	32
3.18	Raking of joints	32
3.19	Brick sills, sill tiles and shrinkage allowance for timber framing	32
4	FRAMING	34
4.01	Verticality or plumbness of stumps or piles	34
4.02	Verticality or plumbness of steel and timber frames and exposed posts	34
4.03	Straightness of steel and timber frame surfaces	34
4.04	Packing under bearers	35
4.05	Timber shrinkage	35
4.06	Treads and risers in timber stairs	35
4.07	Fixing stud walls to concrete slabs	35
4.08	Bottom plates that overhang concrete slabs	36
5	WALL CLADDING	37
5.01	Leaks in wall cladding	37
5.02	Wall cladding	37
6	ROOFING	38
6.01	Leaks in roofing, flashings and accessories	38
6.02	Roof cladding	38
6.03	Roof tiles	38
6.04	Roof tile pointing	38
6.05	Overhang of roofing (tiles and sheet roofing)	39
6.06	Cutting of roof tiles	39
6.07	Dry valley construction	39
6.08	Undulating tiled roof lines	39
6.09	Alignment of trusses	40
6.10	Verticality or plumbness of trusses	40
7	PLUMBING	41
7.01	Plumbing	41
7.02	Positioning of gutters	41
7.03	Water retention in gutters	41
7.04	Joints in gutters	41
7.05	Fixing of gutters and downpipes	41
7.06	Flashings	41
7.07	Water hammer	45
7.08	Pipe penetrations through external walls and inside cupboards	45
7.09	Water supply fixtures	45
7.10	Water drainage from baths, basins, sinks, troughs or the like	45
7.11	Parapet flashings/cappings	45

8	WINDOWS AND DOORS	46
8.01	Installation of external windows and doors	46
8.02	Weather-tightness of windows, doors, and window and door frames	46
8.03	Door furniture	46
8.04	Internal door clearances	46
8.05	Distortion of doors	47
8.06	Sealing of door edges	47
8.07	Operation of windows and doors	47
8.08	Bowed window heads, sills and jambs	47
9	PLASTERING AND RENDERING	48
9.01	Verticality or plumbness of internal and external wall surfaces	48
9.02	Straightness of internal and external wall surfaces	48
9.03	Matching and repairing existing rendered surfaces	48
9.04	Cracking and other blemishes in rendered or hard plastered surfaces on a masonry substrate	49
9.05	Repairs to applied finishes	49
9.06	Movement; Control joints – provision and cracking	49
9.07	Covering movement control joints and damp-proof courses	49
9.08	Cracking in applied finishes used over lightweight substrate	49
9.09	Rendered surfaces	49
9.10	Cracking in external mouldings	50
9.11	Plasterboard sheeting	50
9.12	Other sheeting systems	50
9.13	Level of finish for plasterboard	50
9.14	Cracking in plasterboard, hard plaster and other plaster elements	50
9.15	Cracking in cornices	51
9.16	Cracking at junctions of dissimilar materials	51
9.17	Straightness and alignment of plaster cornices	51
9.18	Peaking or jointing in plasterboard	51
9.19	Nail popping in surfaces	51
10	INTERNAL FIXING	52
10.01	Gaps associated with internal fixing	52
10.02	Joints in fixing of internal mouldings	52
10.03	Architrave quirks	52
10.04	Bench tops, cabinet doors and drawer fronts	52
10.05	Natural materials	52
10.06	Manufactured material	53
10.07	Rectification of defective natural materials and manufactured materials	53
10.08	Joints in timber, stone and laminated bench tops	53
10.09	Sealing around benches and items installed in benches	53

11	FLOOR AND WALL TILING	54
11.01	Floor and wall tiling	54
11.02	Floor and wall tiling where the builder supplies the tiles	54
11.03	Floor and wall tiling where the owner supplies the tiles for laying by the builder	54
11.04	Floor and wall tiles where the owner supplies and lays the tiles	54
11.05	Cracked, pitted, chipped, scratched or loose tiles	54
11.06	Grouting and joints	55
11.07	Flexible sealants to junctions	55
11.08	Uneven tiling	55
11.09	Lippage (stepping) between tiles	56
11.10	Movement joints	56
12	PAINTING	57
12.01	Standard of painting	57
12.02	Surface finish of paintwork	57
12.03	Nail and screw fixings	57
12.04	Natural characteristics and mechanical imperfections/damage	57
12.05	Paint durability	57
13	WET AREAS, DECKS AND BALCONIES	58
13.01	General	58
13.02	Wet areas	58
13.03	Shower recess and components	58
13.04	Leaks in waterproof decks and balconies	58
13.05	Waterproof decks and balconies substrate	59
13.06	Decks and balcony freeboard outside windows and doors	59
13.07	Ponding on waterproof decks and balconies	59
13.08	Calcification and efflorescence associated with decks and balconies	59
14	FLOORS	60
14.01	Timber flooring – shrinkage and swelling	60
14.02	Timber flooring	60
14.03	Gaps in exposed timber flooring	60
14.04	Joint swelling in timber, plywood and particleboard flooring	60
14.05	Nail popping in timber, plywood and particleboard floors	61
14.06	Squeaking floors	61
14.07	Springy floors	61
14.08	Levelness of timber floor	61
14.09	Splitting of timber decking	61
15	ELECTRICAL	62
15.01	Electrical	62

16	POOLS AND SPAS	63
16.01	Concrete pools and spas	63
16.02	Premoulded fibre-reinforced plastic pools and spas	63
16.03	Variations from documented dimensions in concrete pools and spas	63
16.04	Variations from documented datum in concrete pools and spas	63
17	RESTUMPING	64
17.01	Restumping	64
17.02	Consequential damage due to restumping	64
17.03	Floor levels after restumping	64
18	GENERAL	65
18.01	Appliances and fittings	65
18.02	Faults and damage to appliances and fittings	65
18.03	Condensation	65
18.04	Glazing	65
18.05	Lyctus borer	65
18.06	Termites	66
18.07	Termite damage	66
18.08	Cleaning	66
18.09	Maintenance in relation to the performance of building foundations/footings	66
18.10	Floor coverings	68
Appendix A		69
Relevant legislation		69
History of editions		69

A INTRODUCTION

Every year thousands of homes are constructed or renovated in Victoria. While most building projects are completed successfully, occasionally there may be concerns or unmet expectations that result in a dispute.

Most domestic building disputes arise because of disagreements between building owners and builders about the appropriate standards and quality of work. Although the minimum standards for some aspects of construction are regulated, many aspects are not.

Builders and building owners can help prevent disputes by agreeing on the standards and quality of workmanship appropriate for the project when they enter into the building contract, although they cannot apply standards lower than those regulated by Government. However, many domestic building contracts don't include an agreed scope of work and standards.

The *Guide to Standards and Tolerances 2015* (the Guide) has been developed for builders and building owners to use as a convenient reference to the minimum technical standards and quality of work. The Guide provides references to relevant areas of legislation and gives guidance on areas of building standards that are not covered by legislation. Building work that does not meet the standards outlined in the Guide could be considered defective.

The Guide can be used to help resolve disputes about the quality and standards of work. However, it should be understood that this document is intended as a guide only, all other documents stating statutory and contractual requirements take precedence over this Guide.

Each state and territory has legislated to empower the making of building standards and to control the key elements of a domestic building contract.

Regulated building standards are predominantly contained within the National Construction Code Series, Volumes 1 and 2, Building Code of Australia (BCA) which is adopted into law by regulation. In a hierarchy, the regulatory framework for building standards starts with the relevant Act of Parliament or Legislative Assembly, passes to regulations made under that Act, then to the BCA, to Australian Standards and other documents adopted by reference in the BCA.

The *Guide to Standards and Tolerances 2015* is only a guide and an advisory document. It is not a regulated standard and is not part of this hierarchy.

Each state and territory has an Act to regulate the contents of a domestic building contract and the responsibilities of parties. These Acts also require compliance with regulated building standards and require buildings and their materials to be fit for their intended purposes.

In Victoria, the *Domestic Building Contracts Act 1995* defines the term 'defective' as:

"In relation to domestic building work, includes:

- a) a breach of any warranty listed in section 8*
- b) a failure to maintain a standard or quality of building work specified in the contract."*

This Guide can be used to determine whether or not an item is defective only where this cannot be done by reference to the contract documents, the relevant Australian Standards, the BCA or the relevant regulations. Where there is any contradiction or difference between the Guide and an Act, a regulation, the BCA or a building contract, all of these take precedence over the Guide. The Guide does not replace the requirements of these other documents.

Any reference throughout this document to the Building Code of Australia or BCA refers to the National Construction Code Series, Volumes 1 and 2, Building Code of Australia.

Some Australian Standards are referred to (whole or in part) in the BCA. The referenced parts of these Australian Standards take precedence over this Guide.

Fittings, equipment and some materials used in buildings are often supported by manufacturer's installation instructions. The manufacturer's installation instructions take precedence over this Guide.

C APPLICATION OF THE GUIDE

The Guide is intended to inform parties as to what is an acceptable standard of workmanship in domestic building work. It should be noted that builders, subsequent owners and those purchasing from owner-builders or developers can also use this Guide to resolve possible disputes, irrespective of whether or not they were a party to the original building contract.

This edition of the Guide is valid from 30 March 2015 and is applicable to domestic building contracts entered into from that date, or domestic building work that commences from that date (where there is no domestic building contract).

D THE MEASUREMENT OF TIME

Any time period mentioned in the Guide is to be taken to start at the date of completion of the building work as it is legislated in the state or territory where the building work is located.

Generally, the date of completion is the day when the work carried out under the contract is completed in accordance with the terms of that contract, or the day the building owner is given the statutory permit (i.e. Occupancy Permit) or certificate (i.e. Certificate of Final Inspection) that authorises the occupation or use of the building. A more precise definition should be given in the contract associated with the building work.

E THE MEASUREMENT OF TOLERANCES

The tolerances in this Guide apply up to and including the length over which each tolerance is stated to apply. It is not intended that tolerances will be interpolated or proportioned to the actual length of building element measured. For example, where the Guide specifies a 4 mm maximum deviation measured over a 2 m length of wall surface, the Guide means that the same 4 mm deviation is to be applied over a 1 m wall surface or a 500 mm wall surface. The tolerance cannot be interpolated to mean a 2 mm deviation over a 1 m wall surface or 1 mm deviation over a 500 mm wall surface. Similarly, deviations over longer wall surfaces would be defects if the deviation exceeded 4 mm within any 2 m length of that surface.

Horizontal, vertical and diagonal surface tolerances are to be interpreted in the same way.

Horizontal surfaces

Deviations of a horizontal surface are to be measured from a datum nominated in the contract documents or inferred, if none is nominated. Where there is a nominated or inferred datum, the maximum deviation from that datum will not exceed the deviation stated in the Guide. Where no datum is nominated and a datum cannot be inferred, a datum level will be taken to be at the highest or lowest points in the building element, room or area being measured. Refer to diagram E(i).

Horizontal flatness to be measured as shown in Diagrams E(ii) and (iii).

Vertical surfaces

Deviations of a vertical surface from a true vertical plane are to be measured from a plumb line through a plan position or reference point nominated in the contract documents or inferred, if none is nominated. The maximum deviation of a vertical surface from that plumb line will not exceed the deviation stated in the Guide. Refer to diagram E(iv).

Vertical flatness to be measured as shown in Diagrams E(v) and (vi).

Where diagrams are provided for the clarification of details, the diagram shows only detail relevant to the issue and is not intended to be used as a general detail for construction.

DIAGRAM E MEASUREMENT OF HORIZONTAL TOLERANCES

- i) Measurement of deviation from horizontal/level

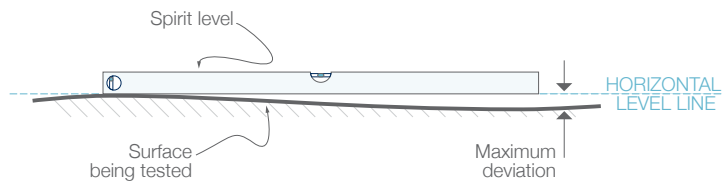

- ii) Measurement of bow

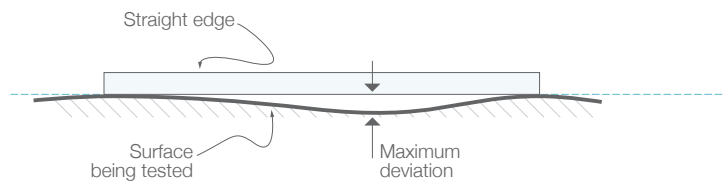

- iii) Measurement of bow (horizontal flatness)

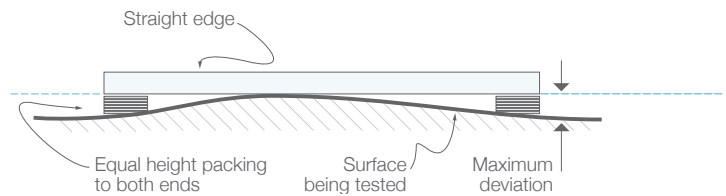
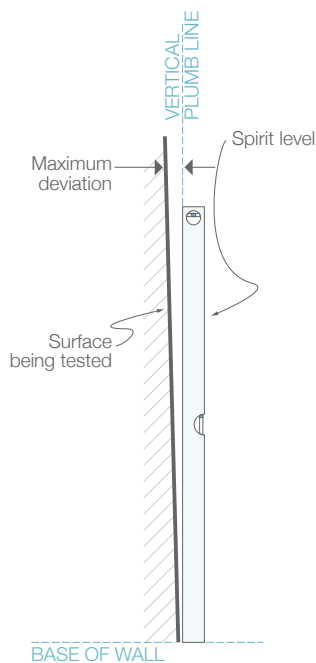
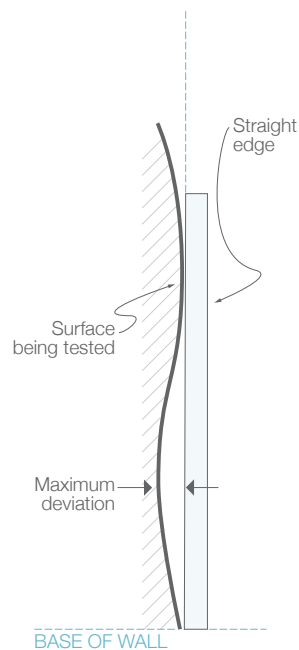

DIAGRAM E MEASUREMENT OF VERTICAL AND INCLINED SURFACES



- iv) Measurement of deviation from vertical/plumb



- v) Measurement of bow (surface flatness)

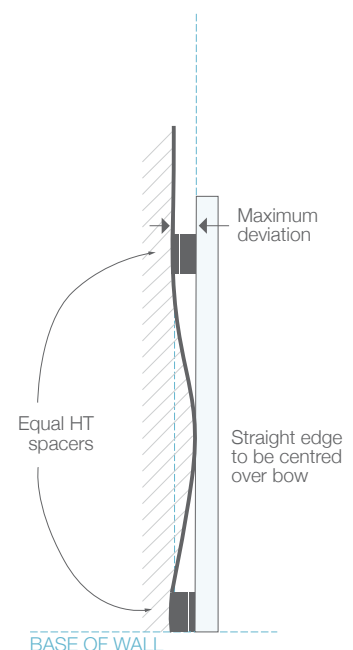

- vi) Measurement of bow (surface flatness)

F INSPECTING SURFACES FROM A NORMAL VIEWING POSITION

Generally, variations in the surface colour, texture and finish of walls, ceilings, floors and roofs, and variations in glass and similar transparent materials are to be viewed where possible from a normal viewing position. A normal viewing position is looking at a distance of 1.5 m or greater (600 mm for appliances and fixtures) with the surface or material being illuminated by 'non-critical light'¹. Non-critical light means the light that strikes the surface is diffused and is not glancing or parallel to that surface.

DIAGRAM F NORMAL VIEWING POSITIONS

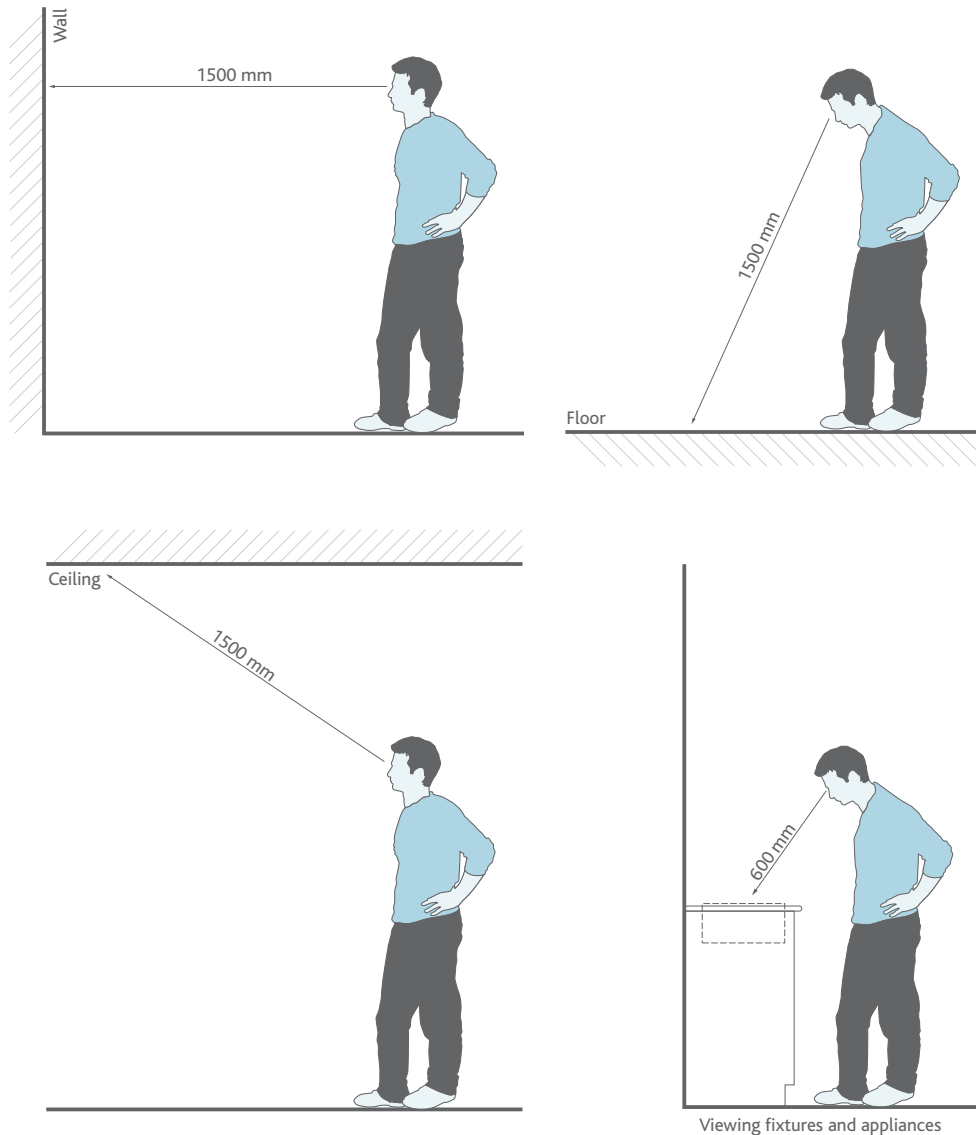

Slight variations in the colour and finish of materials do not always constitute a defect.

¹ Non-critical light is defined in appendix.B3 and D7 Australian Standard AS/NZS 2589. Refer also to CSIRO TR 90/1, Report No. L8 – 1992.

G REMEDIAL WORK

It is envisaged that work to rectify defects will be carried out to match as closely as practical the surrounding materials, finishes, levels and other characteristics of the area to be rectified. In some circumstances, exact matching may not be possible.

Structural rectification work may need to be designed by a structural engineer and inspected or certified by a building surveyor or certifier.

Some remedial work may need to be agreed by way of a contract variation and variation to a building permit or construction certificate before it is carried out.

H RESPONSIBILITY TO RECTIFY

A builder may not be liable to rectify building design and defects that do not arise from the builder's or the builder's subcontractor's work and design. Builders do not have to rectify damage caused by the owner's actions or those of other people engaged by the owner. Builders may be liable to repair damage caused to property in the course of completing their building work.

The following are examples of liability between the owner and the builder:

- a) A builder is unlikely to have to repaint a poorly painted wall that was painted by the building owner.
- b) A builder is unlikely to have to repair a distorted gutter when the damage was caused by an owner placing a ladder against the gutter.
- c) A builder is unlikely to have to repair a stormwater drain that was properly constructed and later blocked by tree roots.
- d) A builder is likely to have to replace untreated pine in an external deck that was installed by the builder instead of the durable timber required for this structure.
- e) A builder is likely to have to repair an existing window in a house that the builder accidentally damaged when constructing another part of the house.

Where there is subsequent damage to the building due to defective building work as a result of the:

- a) owner failing to keep the completed work reasonably maintained, or
- b) unreasonable delay by the owner in notifying the builder of the defect, the builder may not be liable to rectify or compensate the owner.

Where reference is made in the Guide to the 'builder's workmanship', 'work of the builder' or the like, this includes work by contractors or sub-contractors engaged by the builder.

In Victoria, the *Domestic Building Contracts Act 1995* defines the term 'builder' as being:

"A person who, or a partnership which:

- a) carries out domestic building work; or*
- b) manages or arranges the carrying out of domestic building work; or*
- c) intends to carry out, or to manage or arrange the carrying out of, domestic building work."*

I RENOVATIONS, ALTERATIONS AND EXTENSIONS

The standards and tolerances in this Guide only apply to the work covered in the relevant domestic building contract.

It is recommended that before starting new work, the builder informs the owner of any potential circumstances and conditions of the existing building that may have a detrimental effect on the standard of the new building work.

The builder and owner should agree as part of their domestic building contract, or as a written variation to that contract, on the extent of any necessary rectification works that may be required to be carried out to the existing building before commencing that work.

J RECYCLED MATERIALS

The standards and tolerances in this Guide may not apply to construction with second-hand or recycled materials and products. Where there is a contract, the use of second-hand or recycled material must be stated in that contract. Second-hand or recycled materials and products must be fit for purpose and suitable for its' proposed use.

K BUILDING MAINTENANCE – CARE OF THE BUILDING AND SITE AFTER COMPLETION

Building maintenance is an ongoing responsibility for all building owners to ensure their building continues to perform as intended.

Therefore it is recommended owners consider the information in Explanatory Note 2A at the start of Section 2 of this Guide. These documents and other similar documents discuss soil movement and its effects on buildings, including the effects of tree planting and site drainage. Owners can reduce the risk of cracking and damage to building structures by adopting the landscape care suggestions in these documents.

Refer to the following within this Guide:

- a) Explanatory Note at the start of Section 2
- b) Clause 2.01 – Foundation and site drainage – maintenance after occupation
- c) Clause 18.09 – Maintenance.

L AUSTRALIAN STANDARDS AND OTHER REFERENCED MATERIAL

Where this Guide refers to Australian Standards or other reference material, the edition referred to is the one that was current at the time the contract was signed. In many cases this will be a document referred to in the Building Code of Australia that was current at that time.

Where a contract specifies an alternative reference to the ones listed over the page, that reference may be applicable to the work. However, this does not override any statutory obligations to comply with the building legislation.

M SCHEDULE OF REFERENCES USED IN THIS GUIDE

BCA 2014	National Construction Code Series, Volumes 1 and 2, Building Code of Australia (BCA)
AS 1684–2010	Residential timber-framed construction
AS 1860.2–2006	Particleboard flooring – Installation
AS 2047–1999	Windows in buildings – Selection and installation
AS 2783–1992	Use of reinforced concrete for small swimming pools
AS 2796.1–1999	Timber – Hardwood – Sawn and milled products
AS 2870–2011	Residential slabs and footings
AS 3598.1–2007	Ceramic tiles – Part 1: Guide to the installation of ceramic tiles
AS 3598.2–2007	Ceramic tiles – Part 2: Guide to the selection of a ceramic tiling system
AS 3660.2–2000	Termite management – Part 2: In and around existing buildings and structures – Guidelines
AS 3700–2011	Masonry structures
AS 3727–1993	Guide to residential paving
AS 3740–2010	Waterproofing of domestic wet areas
AS 4654–2012	Waterproofing membranes for external above-ground use
AS 4773.2–2010	Masonry in small buildings – Construction
AS/NZS 1839–1994	Swimming pools – Premoulded fibre-reinforced plastics – Installation
AS/NZS 2311–2009	Guide to the painting of buildings
AS/NZS 2589–2007	Gypsum linings – Application and finishing
AS/NZS 3500.3–2012	Plumbing and drainage – Part 3: Stormwater drainage
AS/NZS 4386.1–1996	Domestic kitchen assemblies – Kitchen units
CSIRO document BTF17–2011	Building Technology File 17 – Plant roots in drains – Prevention and cure
CSIRO document BTF18–2011	Building Technology File 18-2011 – Foundation maintenance and footing performance: A homeowner's guide
CSIRO document BTF19–2011	Building Technology File 19 – A builder's guide to preventing damage to dwellings: Part 1 – Site investigation and preparation
CSIRO document BTF22–2008	Building Technology File 22 – A builder's guide to preventing damage to dwellings: Part 2 – Sound construction method
CSIRO TR 90/1, Report No. L8–1992	CSIRO Division of Building Research Report No TR 90/1 : Illumination and decoration of flat surfaces – 5 th Edition (Revised)
ABCB Handbook	Condensation in Buildings (2014) www.abcb.gov.au/en/education-events-resources/publications/abcb-handbooks.aspx

1 SITeworks (PAVING AND LANDSCAPING)

1.01 Cracking in concrete paving

Cracking in concrete is common and is not always attributable to unsatisfactory workmanship. Common causes of cracking include shrinkage stress, stress due to trees, commercial or heavy vehicle traffic, soil movement due to changes in the moisture content as a result of garden watering or drainage problems.

Cracking not attributable to the workmanship of the builder (e.g. trees planted too close to paving, commercial or heavy duty vehicle traffic, use of sprinkler system, etc.) is not a defect.

Cracking in concrete verandahs, garages, carports, paving, patios, driveways, etc. where the builder did not make allowances for shrinkage or general movement of the concrete (e.g. slip joints where required around penetrations such as verandah posts, pipes etc.) shall be assessed in accordance with Table 1.01 and is defective where the limits in that table are exceeded.

TABLE 1.01 CRACKS IN CONCRETE PAVING

Condition	Measure	Limit
Cracking	Crack width	≤ 1.5mm
Subsidence	Heave or slump under 3 m long straight edge (See Note 1 below)	≤ 15mm
Stepping	Relative surface level of adjacent paving elements within the expanse of the main pavement	≤ 5mm

Taken from: AS 3727 – Guide to residential pavements, Table: 1 Performance criteria. Reproduced with permission from SAI Global Ltd under Licence 1407-c122.

Notes to Table 1.01

1. The straight edge is centred over the defect and supported at its ends by equal height spacers. The heave or slump is then measured relative to this straight edge.
2. The stepping criteria apply only to steps within the surface of the main pavement. It shall not be applied where the main pavement abuts other structures such as edging, drainage pits, service pits, minor pavements (such as a pathway adjacent to a driveway) and pavements constructed with materials of a different type.
3. The performance criteria in Table 1.01 apply within the first 12 months after construction of the pavement.
4. The builder may be responsible for works after 12 months if not constructed in accordance with the standard (AS3727).
5. The 12-month period has been adopted as being long enough for a pavement to be subjected to in-service conditions and prior to undue influence of changing environmental conditions such as the effect of tree roots.

1.02 Finish to external concrete paving

Concrete paving finish is defective if it is not consistent in colour, texture and general appearance. Minor variations in finish may occur and may not be considered to be defective.

1.03 Surface drainage

The paving/landscaping should direct surface water away from the building.

Surface water drainage is defective if it is not in accordance with the requirements of the Building Code of Australia.

2 FOOTINGS, SLABS AND SETTING OUT

Explanatory Note 2A:

Footing systems and movement

Footing systems for residential buildings (new buildings or extensions) are designed and constructed according to the building legislation, site-specific soil classification, site conditions and requirements of the development; and can be adversely affected by many factors.

A footing system designed within these parameters is expected to move within acceptable limits to cope with the site-specific conditions. This movement may result in minor distress to the building, including cracking and gaps to the floors, walls and ceiling.

Therefore, distress can only be apportioned to the builder where the distress exceeds the tolerances specified in the Guide as a result of the builder's workmanship.

Abnormal moisture conditions causing building distress may be the result of many contributing factors including:

- landscaping and tree types and proximity
- excessive and localised watering of gardens
- poor building/site maintenance
- water leaks (gutters, pipes and appliances)
- adverse effects from adjoining properties.

Causes of building distress are often difficult to identify and explain, and on occasion it is difficult to identify the responsible party or parties.

Further information on foundation systems and movement can be found in the following reference material:

- CSIRO Document – Building Technology File 17 – Plant roots in drains – Prevention and cure
- CSIRO Document – Building Technology File 18-2011 – Foundation maintenance and footing performance: A homeowner's guide
- CSIRO Document – Building Technology File 19 – A builder's guide to preventing damage to dwellings: Part 1 – Site investigation and preparation
- CSIRO Document – Building Technology File 22 – A builder's guide to preventing damage to dwellings – Part 2 – Sound construction method
- Australian Standard 2870-2011: Residential slabs and footings.

2.01 Foundation and site drainage – maintenance after occupation

The builder is not responsible for foundation movement caused by activities that were not documented at the time of entering into the contract or as variation to that contract, or that are undertaken by the owner. These include paving, landscaping, planting trees and drainage works after the site is handed over to the owner.

The builder is not responsible for foundation movement caused by the owner's failure to maintain drainage systems after the site is handed over to the owner.

Refer also to Item K of this Guide.

2.02 Footings and slabs

Slabs and footings are defective if they fail because they are not designed and constructed in accordance with the Building Code of Australia or AS 2870.

Slabs and footings are defective where foundation movement is caused by factors that were present during construction (e.g. poor founding material, excessive wetting and drying of site, number, type proximity and maturity of trees/shrubs or lack of site drainage). Slab and footing movement should be assessed in accordance with Table 2.10 and Table 3.02 of this Guide.

2.03 Setting out the site

A building set out is defective where the set out has failed to comply with the requirements of the approved drawings, the allotment Certificate of Title, planning or development approval, relevant planning overlays and schemes and building regulations.

Building work must not encroach over an allotment boundary unless authorised/approved to do so. A builder must ensure footings, gutters and any other part of the building work does not encroach an allotment boundary unless authorised/approved to do so.

2.04 External building dimensions

Departures from documented external dimensions of buildings are defects if they exceed $L/200$ where L is the documented overall length of wall, or 5 mm, whichever is the greater.

2.05 Measuring internal building dimensions

Unless shown otherwise, dimensions shown on drawings for internal walls always refer to the structure's dimensions. Structure means masonry and timber framing and does not include finishes such as plasterboard, render and skirtings. The internal room sizes will be different when thicknesses of internal finish materials are taken into account.

2.06 Building dimensions

Departures from the documented set out for service rooms such as bathrooms, toilets, laundries, kitchens etc. are defects if they exceed $L/200$ or 5 mm, whichever is the greater, where L is the documented dimension.

Departures from the documented set out for habitable rooms and areas, such as bedrooms, dining rooms, lounge and living rooms, family rooms, studies, halls, entries and stairways are defects if they exceed $L/100$ or 5 mm, whichever is the greater, where L is the documented dimension.

Departures from documented set out for external elements such as garages, carports, verandahs, decks, patios, etc. are defects if they exceed $L/100$ or 5 mm, whichever is the greater, where L is the documented dimension. Masonry work shall comply with Table 3.04.

The set out is defective where a specific fixture or feature is required to be accommodated, and such documented dimensions to accommodate that fixture or feature are not provided.

Ceiling heights shall be in accordance with the requirements of the Building Code of Australia, unless a greater height is specified in the contract.

2.07 Finished floor levels

Finished floor levels (FFL) or reduced levels (RL) are defective where they do not comply with specified planning and/or building permit requirements.

In other cases, FFL or RL are defective where:

- a) they depart from the documented RL or FFL by more than 40 mm; or
- b) floors are documented to be on the same plane but are constructed on different planes; or
- c) the building work is an extension or addition and new floor levels do not match the existing building floor levels. Also refer to Item I of this Guide.

2.08 Levelness of concrete floors

Except where documented otherwise, new floors are defective if within the first 24 months of handover they differ in level by more than 10 mm in any room or area, or more than 4 mm in any 2 m length. The overall deviation of floor level to the entire building footprint shall not exceed 20 mm. Refer to Item I of this Guide where the new floor is to abut an existing floor.

2.09 Dimensions of building elements

Deviations from the documented height or cross-sectional dimension of building elements such as beams and posts are defective if they exceed $L/200$ where L is the documented dimension or 5 mm, whichever is the greater.

2.10 Cracks in concrete slabs

Refer to Table 2.10 for descriptions of categories of cracks.

Cracks to slabs are defective where they are Category 3 and 4.

Category 1 and 2 cracks to slabs are to be monitored for a period of 12 months. At the end of the monitoring period, cracks are defective if they are greater than category 2 and attributed to the actions of the builder.

TABLE 2.10 CLASSIFICATION OF DAMAGE TO CONCRETE FLOORS

Description of typical damage	Approximate crack width limit in floor	Change in offset from 3 m straight edge placed over defect	Damage category
Hairline cracks, insignificant movement of slab from level	< 0.3 mm	< 8 mm	0 Negligible
Fine but noticeable cracks. Slab reasonably level	< 1.0 mm	< 10 mm	1 Very slight
Distinct cracks. Slab noticeably curved or changed in level	< 2.0 mm	< 15 mm	2 Slight
Wide cracks. Obvious curvature or change in level	2 mm to 4 mm	15 mm to 25 mm	3 Moderate
Gaps in slab. Disturbing curvature or change in level	4 mm to 10 mm	> 25 mm	4 Severe

Taken from AS 2870: Residential slabs and footings – Construction, Table C2: Classification of damage with reference to concrete floors. Reproduced with permission from SAI Global Ltd under Licence 1407-c122.

Notes to Table 2.10

1. The straightedge is centred where possible over the defect, and supported at its ends by equal height spacers. The change in offset is then measured relative to this straightedge, which is not necessarily horizontal.
2. Local deviation of slope, from the horizontal or vertical, of more than 1:100 will normally be clearly visible. Overall deviations in excess of 1:150 is undesirable.
3. Account should be taken of the past history of damage in order to assess whether it is stable or likely to increase.

2.11 Finish to concrete slabs

The finish to a concrete slab is defective if it is not suitable for the documented applied finishes such as tiles, polished concrete, carpet or sheet flooring, including set downs where required.

2.12 Repairs to exposed concrete slabs

Repairs, where failure has been due to cracking and/or movement, may involve the removal of the affected area. The repair is defective if it does not, as closely as practicable match the existing work in appearance, colour and texture. Minor variations in finish may not be considered to be defective.

3 MASONRY

3.01 Masonry types

This section includes tolerances for generally-used types of masonry, including:

- a) clay and concrete brick construction
- b) clay and concrete brick veneer construction
- c) concrete block construction.

The tolerances for the above may not always be appropriate for some types of masonry construction, such as pre-fabricated masonry panels, aerated concrete blocks, irregular cut stone, rustic finish masonry with irregular edges and appearance, etc. In these cases, parties must obtain the manufacturer’s advice.

3.02 Damage to masonry walls

Refer to Table 3.02 for descriptions of categories of damage.

Category 3 or greater damage to walls is defective and requires investigation, stabilisation, monitoring and rectification work, which may include breaking out and replacing sections of the wall.

Category 2 cracks to walls are to be monitored for a period of 12 months. At the end of the monitoring period, a crack rated at Category 2 or above is defective and requires rectification. Category 2 damage is defective and requires minor repair work such as repointing.

TABLE 3.02 DAMAGE TO WALLS CAUSED BY MOVEMENT OF SLABS AND FOOTINGS AND OTHER CAUSES

Description of typical damage and required repair	Crack width limit	Damage Category
Hairline cracks	< 0.1 mm	0 Negligible
Fine cracks that do not need repair	< 1 mm	1 Very slight
Cracks noticeable but easily filled. Doors and windows stick slightly	< 5 mm	2 Slight
Cracks can be repaired and possibly a small amount of wall will need to be replaced. Doors and windows stick. Service pipes can fracture. Weather tightness often impaired	5 mm to 15 mm (or a number of cracks 3 mm or more in one group)	3 Moderate
Extensive repair work involving breaking-out and replacing sections of walls, especially over doors and windows. Window and doorframes distort. Walls lean or bulge noticeably. Some loss of bearing in beams. Service pipes disrupted	15 mm to 25 mm but also depends on number of cracks	4 Severe

Taken from AS 2870: Residential slabs and footings – Construction, Table C1: Classification of damage with reference to walls. Reproduced with permission from SAI Global Ltd under Licence 1407-c122.

Notes to Table 3.02

1. Where the cracking occurs in easily repaired plasterboard or similar clad-framed partitions, the crack width limits may be increased by 50 per cent for each damage category.
2. Crack width is the main factor by which damage to walls is categorised. The width may be supplemented by other factors, including serviceability, in assessing category of damage.
3. In assessing the degree of damage, account shall be taken of the location in the building or structure where it occurs, and also of the function of the building or structure.

3.03 Movement; control joints in masonry walls

Where required, control joints are defective if not installed as required by the Building Code of Australia or in accordance with the contract documents.

Control joints are defective if they do not extend through the full thickness of masonry skin.

Where required, control joints are defective if they are not sealed in accordance with AS 3700.

Unless documented otherwise, flexible mastic or sealant is defective if it does not match as close as practicable the colour of the adjacent surface, and has not been applied in accordance with the manufacturer's installation instructions.

3.04 Masonry construction

Masonry is defective if it exceeds the tolerances set out in Table 3.04.

TABLE 3.04 TOLERANCES IN MASONRY CONSTRUCTION

Item	Column 1 (Structural tolerance)	Column 2 (Non-structural tolerance)	Reference
A Horizontal position of any masonry element documented or shown in plan at its base or at each storey level	15 mm	15 mm	Diagram 3.04(A) Do not exceed set out tolerances in clause 2.03
B Relative displacement between loadbearing walls in adjacent stories intended to be in vertical alignment	10 mm	10 mm	Diagram 3.04(B)
C Maximum deviation from plumb within a storey from a vertical line through the base of the member	The lesser of 10 mm per 3 m of height or 0.05 times the thickness of the leaf	10 mm	Diagram 3.04(C)
D Maximum deviation from plumb in total height of the building (from the base)	25 mm	25 mm	Diagram 3.04(D)
E Maximum horizontal or vertical deviation of a surface from a plane surface (bow) in any 2 m length	5 mm	3 mm	Diagram E(ii) and E(v) From page 13
F Deviation (step) of any exposed masonry surface from any adjacent exposed masonry surface. The bow provision of Item E above also applies	Not applicable	2 mm	Diagram 3.04(D)
G Deviation of bed joint from horizontal, or from the level documented or shown in elevation	10 mm in any 10 m length, 15 mm in total	10 mm in any 10 m length, 15 mm in total	Diagram 3.04(G)
H Deviation from documented thickness of bed joint	3 mm	3 mm	Diagram 3.04(H)
I Minimum perpend thickness	5 mm	5 mm	Diagram 3.04(I, J)
J Deviation from documented thickness of perpend	10 mm maximum	5 mm	Diagram 3.04(I, J)
K Maximum difference in perpend thickness in any wall	No limit	8 mm	Diagram 3.04(I, J)
L Deviation from documented width of cavity minimum width as required by the Building Code of Australia	15 mm	15 mm	Diagram 3.04(L)

Taken from AS 3700 – Masonry structures, Table 12.1: Tolerances in masonry construction. Reproduced with permission from SAI Global Ltd under Licence 1407-c122.

Notes to Table 3.04

- Items H, I, J and K are not applicable to thin-bed mortar joints.
- Items I and J tolerances are not applicable when perpend joints are not filled with mortar as is the case with some horizontally cored masonry that is not required to resist horizontal bending.
- Items E, F and I only apply to the true, fair or finish face of single skin masonry.
- For structural tolerances in masonry refer to the Building Code of Australia.
- The tolerances within the table apply to each separate masonry panel face.
- The nominal size of mortar joints is to be 10 mm unless specified otherwise.

DIAGRAMS FOR TABLE 3.04 TOLERANCES IN MASONRY CONSTRUCTION

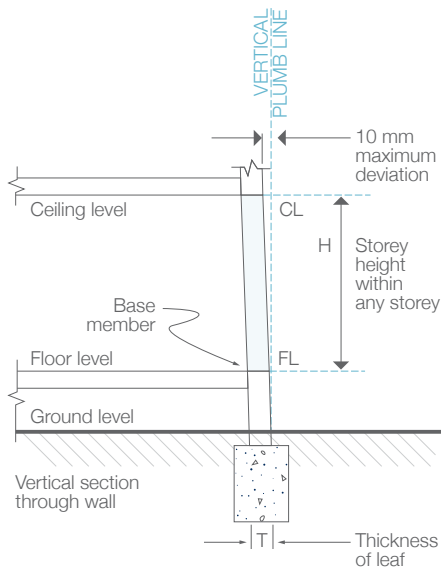
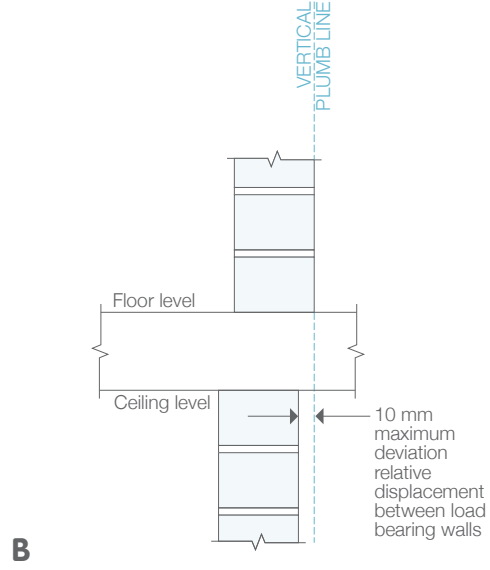
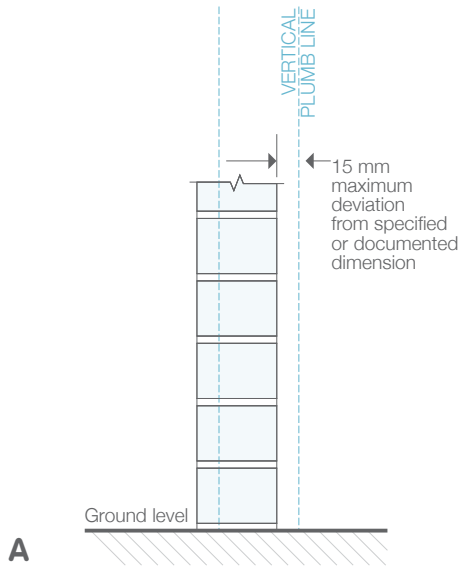

Formula:
Maximum deviation from plumb within any storey

Structural lesser of $\pm \left(\frac{10H}{3}\right)$ or $\pm 0.05T$

H measured in m
T measured in mm

For example if a storey height, H= 4000 mm and leaf thickness, T= 190 mm. Tolerance is the lesser of $10 \times 4.0 \div 3 = 13.3$ mm or $0.05 \times 190 = 9.5$ mm ie. 9.5 mm

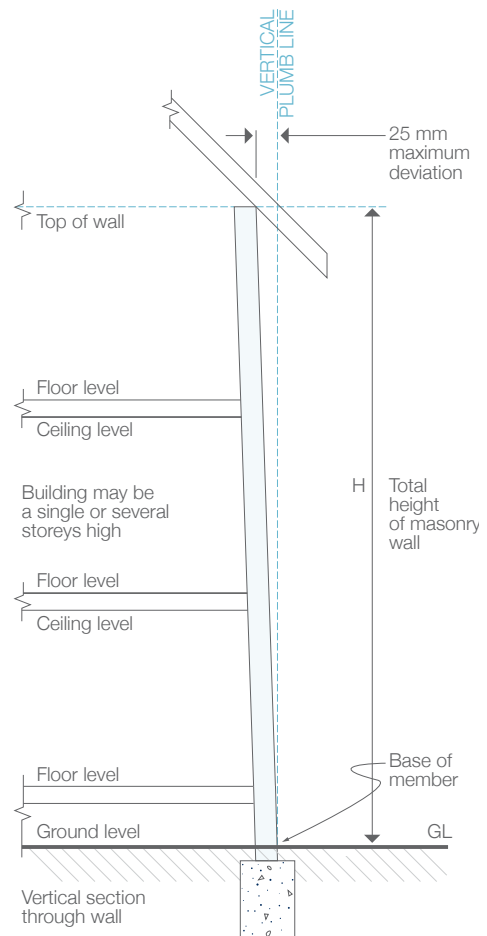

DIAGRAMS FOR TABLE 3.04 TOLERANCES IN MASONRY CONSTRUCTION

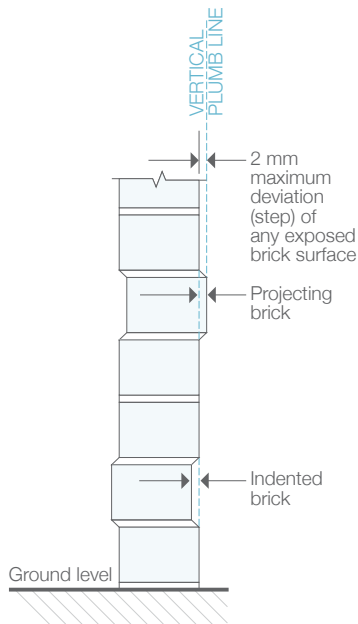

F

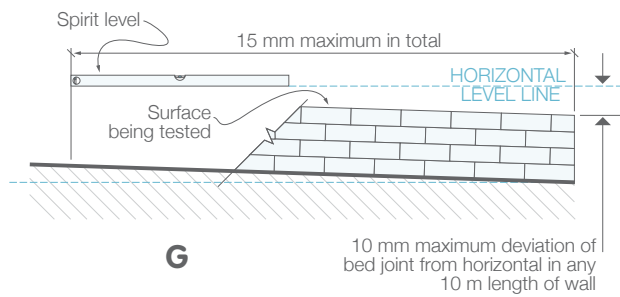

G

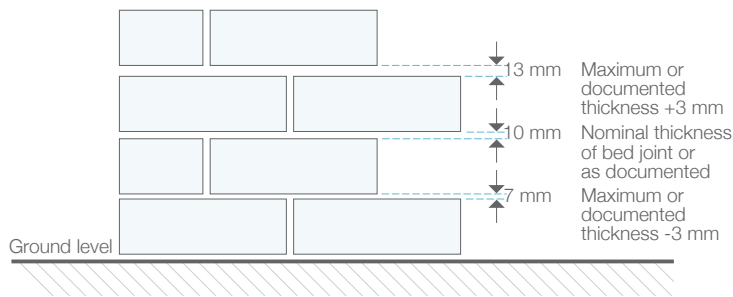

H

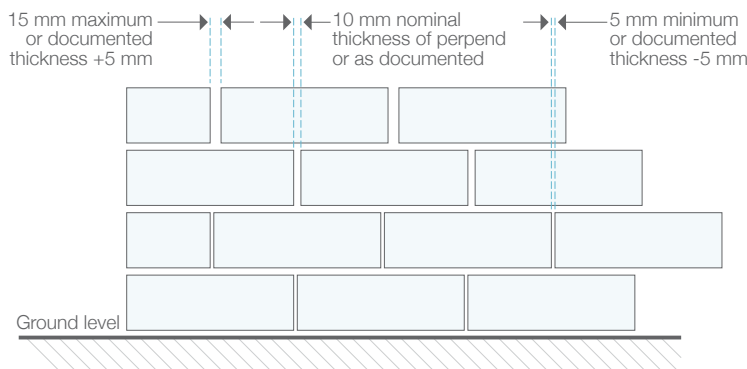

I, J Note: Table 3.04 (K) provides that maximum difference in width of perpend in any wall must not exceed 8 mm.

DIAGRAMS FOR TABLE 3.04 TOLERANCES IN MASONRY CONSTRUCTION

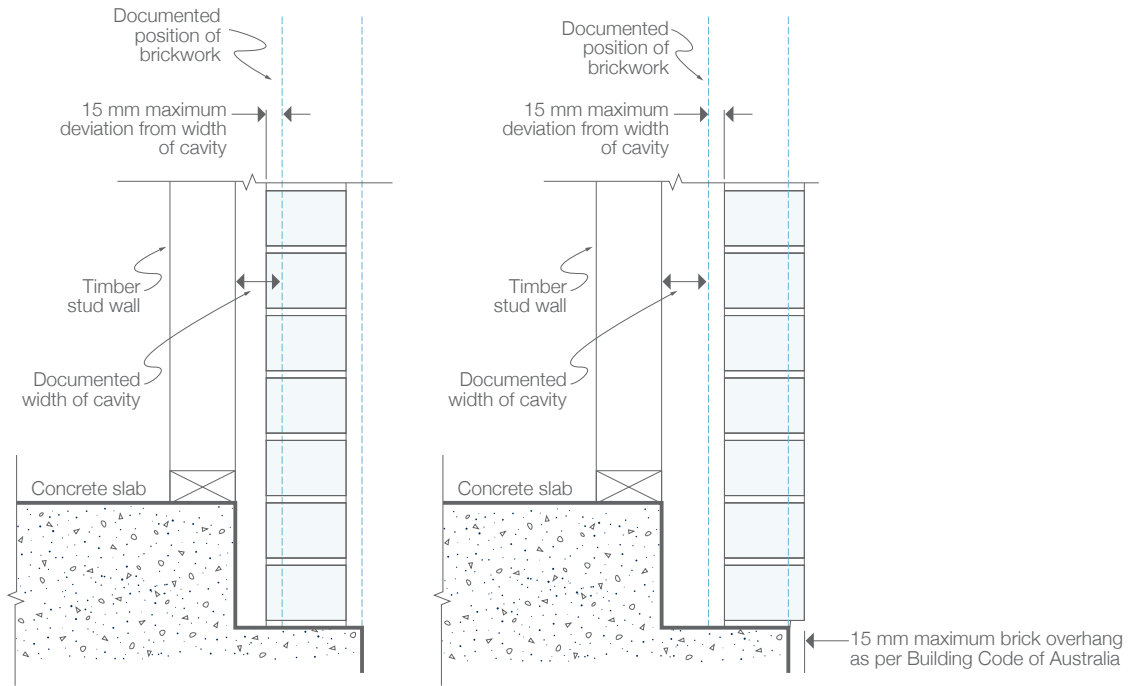

L Note: Refer to the Building Code of Australia for minimum cavity width.

3.05 Blending and matching of masonry – repair work

If matching masonry in alteration and repair work is not reasonably possible, builders should use a practical approach and where possible a physical joint, door, window, downpipes or other similar separating materials should be incorporated to 'break' the visual impact.

Mortar repairs are defective if they do not match the existing mortar as closely as practicable.

A perfect colour match may not be possible and differences may diminish over time.

Some variation of masonry features such as colour, texture and pattern are to be expected between batches.

3.06 Blending and matching of masonry – new work

To avoid inconsistency in appearance, where practicable, masonry units for the building should be obtained from the same batch.

Masonry areas that vary in colour are defective if the units are not mixed and/or distributed in accordance with the manufacturer's installation instructions.

Display panels and display homes may be taken as representative of the range of variations to be expected.

3.07 Masonry facing

Unless documented otherwise, masonry is defective if it is not laid with true, fair or finish face outwards.

Unless documented otherwise, masonry faces are defective if they are not cleaned and free of excess mortar.

3.08 Mortar for masonry

Mortar is defective if it is not in accordance with the requirements of the Building Code of Australia or the contract specifications.

3.09 Voids and holes in mortar

Voids and holes in mortar in masonry walls, with the exception of weepholes and vents, are defective if they are visible from a normal viewing position.

3.10 Cracked masonry unit

It is characteristic of some masonry units to have surface cracks or crazing as part of the manufacturing process. These are not defective unless they result in the complete fracture of the unit.

Masonry units that are damaged, cracked or otherwise visually inconsistent with the overall characteristics of the masonry units are defective.

3.11 Cleaning, mortar smears and stains

Stains, mortar smears and damage caused by cleaning are defective if they are visible from a normal viewing position.

3.12 Masonry inside garages and similar spaces and under applied finishes

Structural masonry that is visible inside a garage or similar space or through an applied finish is defective if it does not comply with the tolerances in column 1 of Table 3.04. However, these tolerances do not apply to the non-face side of single skin masonry.

Non-structural masonry that is visible inside a garage or similar space or through an applied finish is defective if it does not comply with the tolerances in column 2 of Table 3.04. However, these tolerances do not apply to the non-face side of single skin masonry.

When there is an applied finish such as render, where the joints are not intended to be visible, masonry need not be saw cut and $\frac{1}{4}$ or $\frac{3}{4}$ units may be used in lieu of full masonry units.

3.13 Vertical alignment of perpend joints

A line of masonry perpend is defective if it exceeds a maximum deviation from vertical alignment of 20 mm per 2 m height of wall, measured from centre to centre of perpend joints.

3.14 Horizontal alignment of bed joints

Bed joints in walls including adjacent isolated piers and either side of openings and control joints are defective if they are not on the same horizontal plane, or do not comply with Item G of Table 3.04 of this Guide.

3.15 Base bed joint and base row of masonry

Exposed base bed joints above the finished ground level are defective if they exceed 20 mm in thickness.

Base bed joints that are not exposed above the finished ground level are defective if they are greater than 40 mm.

Split masonry units and units on edge used in the base course of masonry walls are defective if they are exposed.

3.16 Masonry that overhangs concrete slabs

A masonry course is defective if it is laid on a concrete slab or strip footing so as to project over the edge of the slab or footing by more than 15 mm.

3.17 Damp proof courses

Damp proof courses are defective if they are not installed in accordance with the Building Code of Australia.

3.18 Raking of joints

Unless documented otherwise, mortar joints in masonry units are defective if they are raked out to a depth of more than 10 mm or are not consistent in depth throughout.

3.19 Brick sills, sill tiles and shrinkage allowance for timber framing

Window frames, sill tiles and sill bricks are defective if they are distorted or dislodged.

Eaves where the soffit and the masonry meet are defective if they are not installed with the minimum clearances set out in Table 3.19.

Brick sills are defective if they are not laid with a consistent slope to each elevation and adequate slope to provide drainage away from the opening.

Refer also to Diagram 3.19.

TABLE 3.19 SHRINKAGE ALLOWANCE FOR TIMBER FRAMING

Type of frame/ construction	Approximate total shrinkage (mm)			
	Single storey		Two storey	
	Slab to lower floor	Timber to lower floor	Slab to lower floor	Timber to lower floor
Fully seasoned timber frame (bearers, joists and wall frame)	0	0	0	0
Seasoned softwood wall frame, unseasoned softwood joists, bearers in-line	0	10	10	20
Unseasoned softwood wall frame, seasoned joists and bearers	5	5	11	11
Unseasoned hardwood wall frame, seasoned joists and bearers	9	9	22	22
Unseasoned hardwood wall frame, unseasoned softwood joists, bearers in-line	9	19	32	42
Seasoned softwood frame, unseasoned hardwood bearers and joists	0	22	20	42

Taken from AS 4773.2-2010 – *Masonry in small buildings – Construction*, Table 9.1: Minimum clearance for timber framing shrinkage. Reproduced with permission from SAI Global Ltd under Licence 1407-c122.

DIAGRAM 3.19 SHRINKAGE ALLOWANCE FOR TIMBER FRAMING

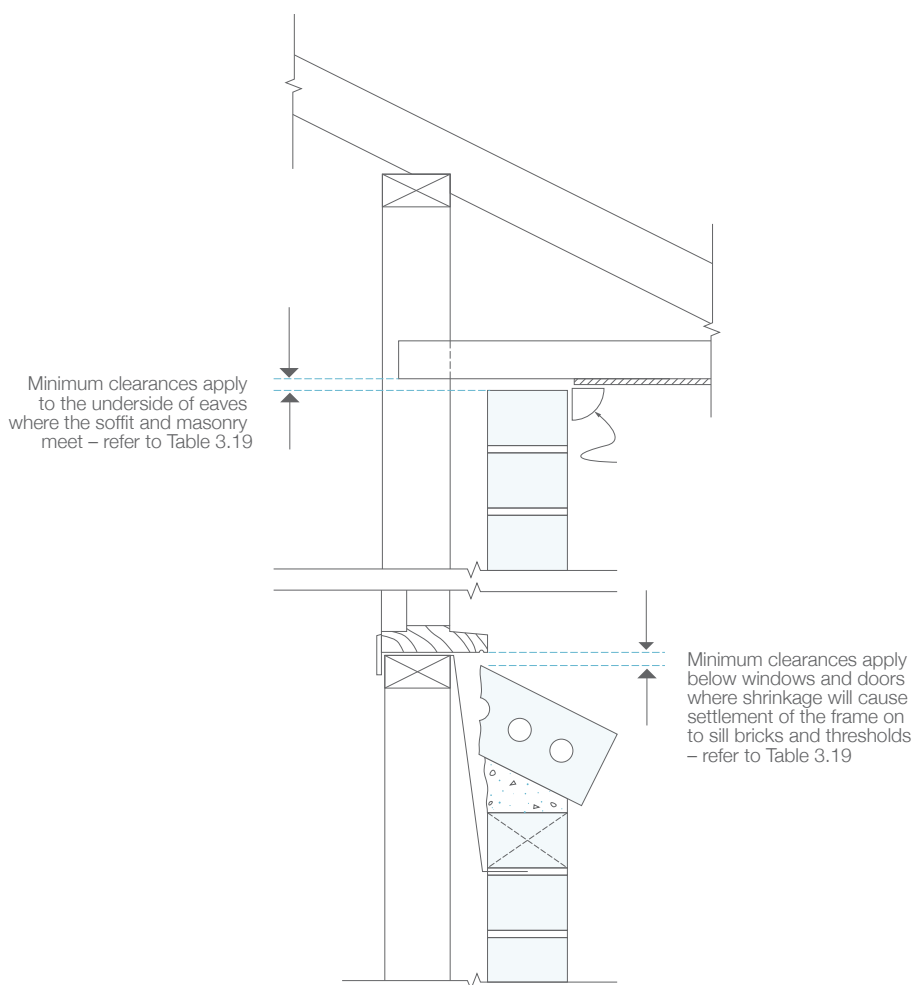

4 FRAMING

4.01 Verticality or plumbness of stumps or piles

Stumps or piles are defective if they deviate from vertical by more than:

- 10 mm for stumps or piles up to 1 m in height
- $L/100$ for stumps or piles up to 2 m in height
- 20 mm for stumps or piles greater than 2 m in height.

Refer to Diagram 4.01.

DIAGRAM 4.01 VERTICALITY OR PLUMBNESS OF STUMPS OR PILES

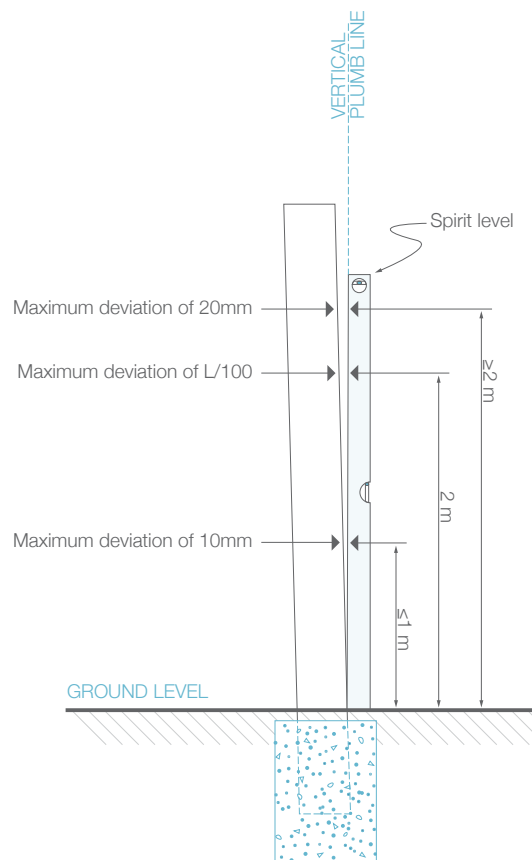

4.02 Verticality or plumbness of steel and timber frames and exposed posts

Posts and wall frames are defective if they deviate from vertical by more than 5 mm over a 1.8 m height. Refer to Diagram E.

4.03 Straightness of steel and timber frame surfaces

Frames are defective if they deviate from plane (horizontal or vertical bow) by more than 4 mm in any 2 m length of wall. Refer to Diagram E.

4.04 Packing under bearers

Packing to stumps or piers under bearers is defective if it is not made of durable, non-compressible materials, such as engineered plastic packers, or does not provide the minimum bearing area required by AS 1684, is more than a total thickness of 20 mm, or is not fixed in a proper and workmanlike manner.

4.05 Timber shrinkage

Timber is defective if it has shrunk more than 10 per cent for unseasoned timber, or three per cent for seasoned timber.

4.06 Treads and risers in timber stairs

Timber stairs are defective if they do not comply with the requirements of the Building Code of Australia.

The finished riser and going dimensions after installation of floor finishes nominated in the contract are defective if they do not result in consistent riser and going dimensions as required by the BCA.

A tolerance of up to 5 mm consistent throughout the flight of the stair from the nominated dimensions in the approved documents is considered acceptable.

This tolerance shall not be applied to allow for poor construction practice.

4.07 Fixing stud walls to concrete slabs

Bottom plates are defective if they are not fixed to concrete slabs in accordance with AS 1684.

Depending on the manufacturer's requirements for the concrete nail/masonry anchor used and the required uplift pull-out force and wind category, the distance of the fixing from the edge of the slab is required to be between 50 mm and 70 mm for standard 20 MPa concrete.

The fixing point cannot be less than five times the diameter of the fastener from the edge of the timber plate which equates to 25 mm for a 5 mm diameter nail and 50 mm for a 10 mm diameter masonry anchor.

4.08 Bottom plates that overhang concrete slabs

Bottom plates that are less than 90 mm wide and overhang concrete slabs are defective.

Bottom plates that are 90 mm wide or greater and overhang concrete slabs by more than 10 mm are defective.

Minimum cavity widths as required by the Building Code of Australia shall be maintained.

DIAGRAM 4.08 BOTTOM PLATES THAT OVERHANG CONCRETE SLABS

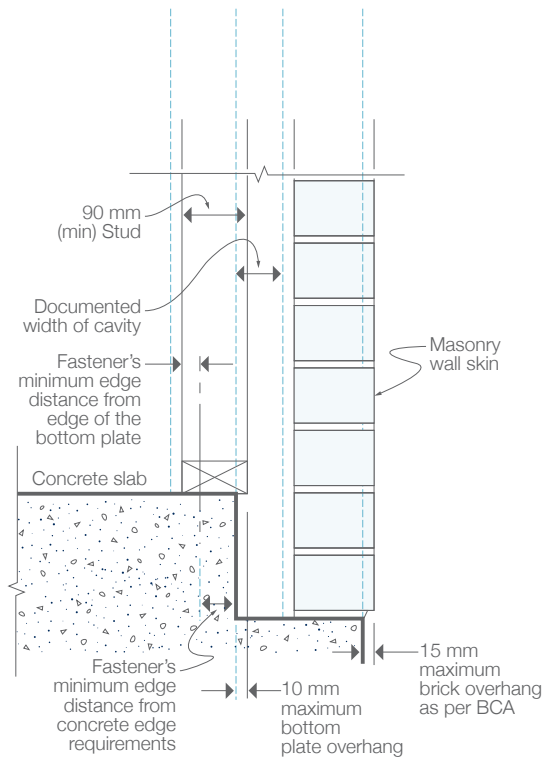

5 WALL CLADDING

5.01 Leaks in wall cladding

Completed wall cladding and accessories are defective if they leak under normal weather conditions and are due to the builder's workmanship, cause unhealthy or dangerous conditions, loss of amenity for occupants, undue dampness or deterioration of building elements.

5.02 Wall cladding

Staining, folds, splits, dents, open joints between panels, cracking and other distortions in wall cladding are defective if they are visible from a normal viewing position at ground level or an upper floor level.

Any unintended corrosion of metal wall cladding is defective unless it is due to lack of maintenance by the owner.

6 ROOFING

6.01 Leaks in roofing, flashings and accessories

Roofing, including flashings and accessories, is defective if it leaks under normal weather conditions and is due to the builder's workmanship, causes unhealthy or dangerous conditions, loss of amenity for occupants, undue dampness or deterioration of building elements.

6.02 Roof cladding

Staining, folds, splits, dents, open joints between panels, cracking and other distortions in roof cladding is defective if it is visible from a normal viewing position at ground level or an upper floor level.

Any corrosion of roof cladding is defective unless it is caused by a lack of maintenance or damaged by the owner.

6.03 Roof tiles

Roof tiles are defective if they do not conform to the manufacturer's sample. Irregularities in tiles are defects if they are visible from a normal viewing position at ground or upper floor levels.

Minor surface marks or blemishes arising from the tile manufacturing process are not defective.

Cracked or broken roof tiles are defective if caused by the builder's workmanship.

6.04 Roof tile pointing

Unless documented otherwise, the absence of pointing where required is defective.

Pointing is defective if it becomes dislodged or washed out.

The pointing is defective if it is not uniform in colour, texture and trowelled off to provide a neat appearance. The rectification of pointing shall match the existing colour and texture as close as practicable.

Minor cracking of pointing is not defective.

6.05 Overhang of roofing (tiles and sheet roofing)

Tiled roofing is defective if tiles overhang the inside face of a gutter by less than 35 mm or by more than 65 mm.

Sheet roofing is defective if it overhangs the inside face of a gutter by less than 50 mm or by more than 65 mm.

DIAGRAM 6.05 OVERHANG FOR ROOFING

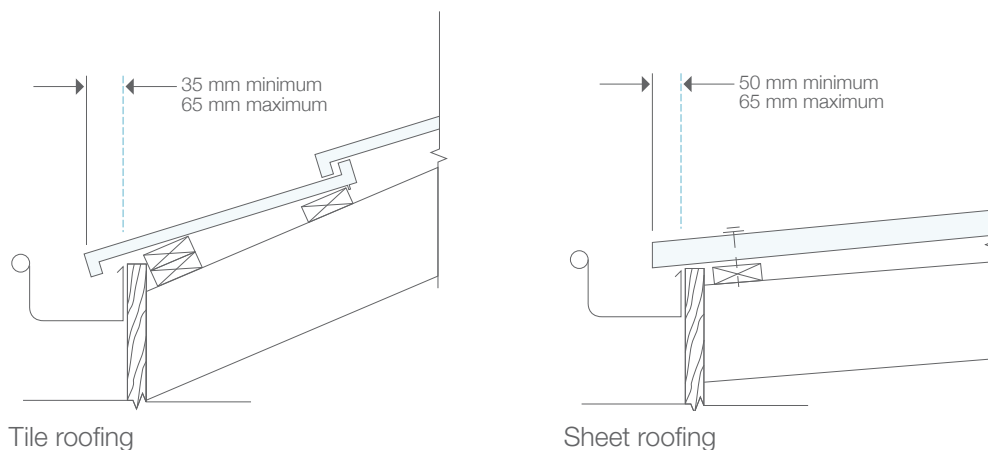

6.06 Cutting of roof tiles

Tiles are defective if they are not cut neatly to present a straight line at ridges, hips, verges and valleys.

6.07 Dry valley construction

Dry valleys, where they are documented, are defective if they are not constructed in accordance with the Building Code of Australia or any relevant instructions from roofing tile associations or the manufacturer's installation instructions.

6.08 Undulating tiled roof lines

Undulations in the line of roof tiles are defective if the variation exceeds 20 mm in any 4 m length measured in the roof plane.

6.09 Alignment of trusses

Trusses or chords of trusses that bow more than the lesser of $L/200$ or 50 mm are defective; where L is the length of the truss or chord.

DIAGRAM 6.09 ALIGNMENT OF TRUSSES

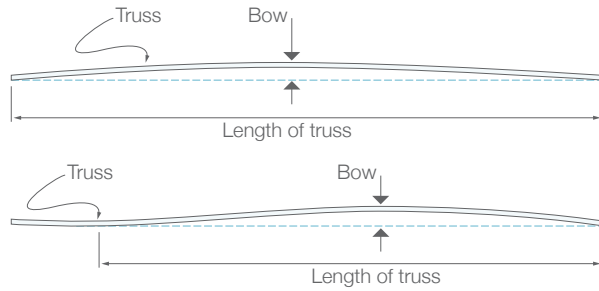

6.10 Verticality or plumbness of trusses

Trusses or parts of trusses that are erected with a vertical deviation more than the lesser of $H/50$ or 50 mm are defective, where H is the height of the truss.

DIAGRAM 6.10 VERTICALITY OR PLUMBNESS OF TRUSSES

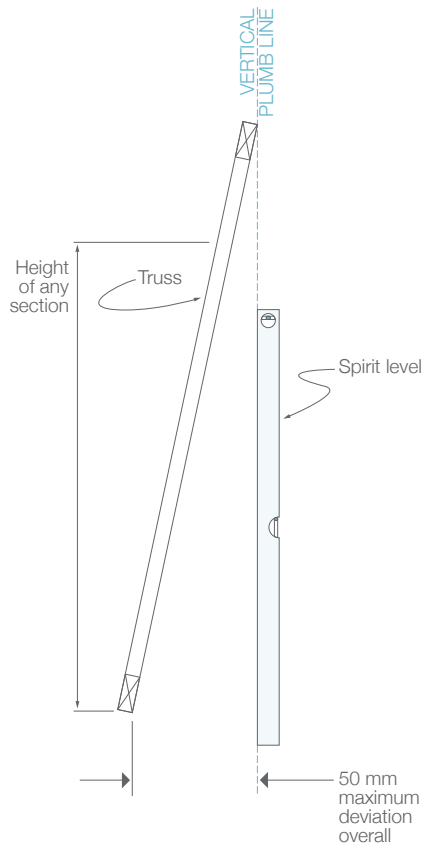

7 PLUMBING

7.01 Plumbing

Plumbing work is defective if it does not comply with the relevant plumbing regulations and the contract documents.

The builder shall provide the owner with a compliance certificate from the plumber when a certificate is required to be issued.

7.02 Positioning of gutters

Unless documented otherwise, installation of gutters is defective if the fascia, when viewed from a normal viewing position, is:

- a) visible above a gutter
- b) not concealed by a flashing finished to match the gutter.

7.03 Water retention in gutters

Gutters are defective if they retain a depth of more than 10 mm of water.

7.04 Joints in gutters

Unless documented otherwise, gutters are defective if they have joints lapped less than 25 mm. Laps that are not in the direction of flow to the outlet are defective.

Joints that leak are defective.

7.05 Fixing of gutters and downpipes

Gutters and downpipes are defective if they are not securely fixed.

7.06 Flashings

Flashings are defective if they are not provided in accordance with the requirements of the Building Code of Australia.

Wall and step flashings, and sloping flashings cut into walls are defective if they do not incorporate weathering folds, anti-capillary breaks and sealing, or do not enter the masonry walls by at least 15 mm as shown in Diagram 7.06(A) and Diagram 7.06(B).

Pressure flashings are defective if they are not fixed on appropriate surfaces, or are not fixed in accordance with Diagram 7.06(C).

DIAGRAM 7.06 FLASHINGS

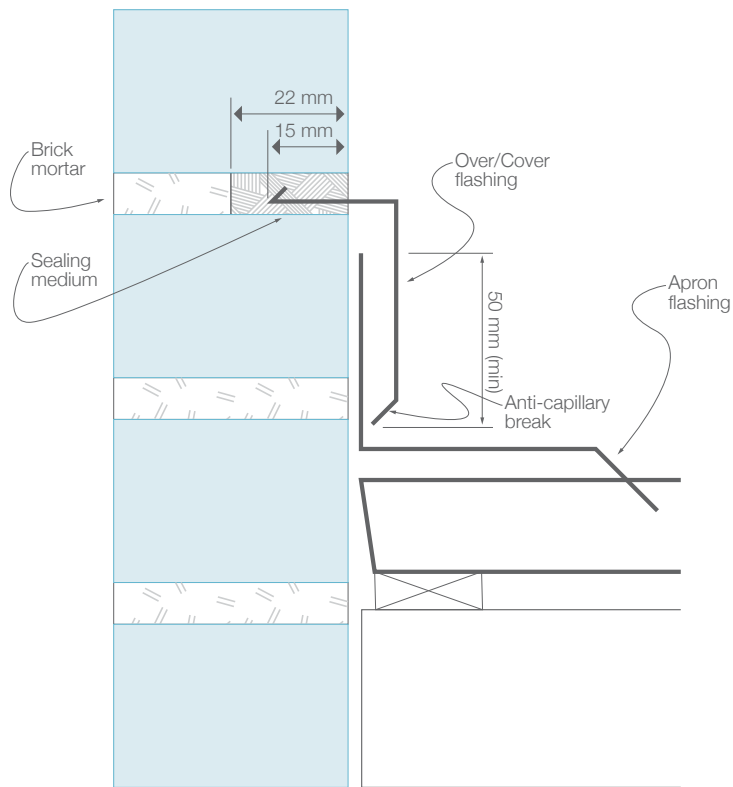
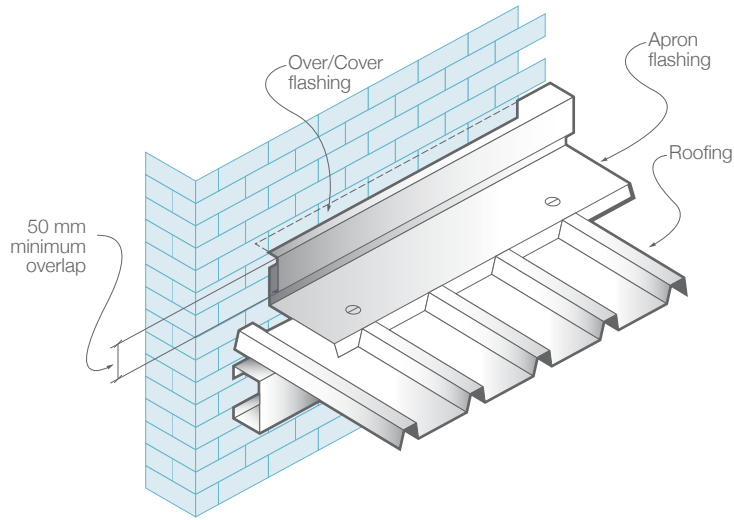

A Traditional raked joint and step method

DIAGRAM 7.06 FLASHINGS

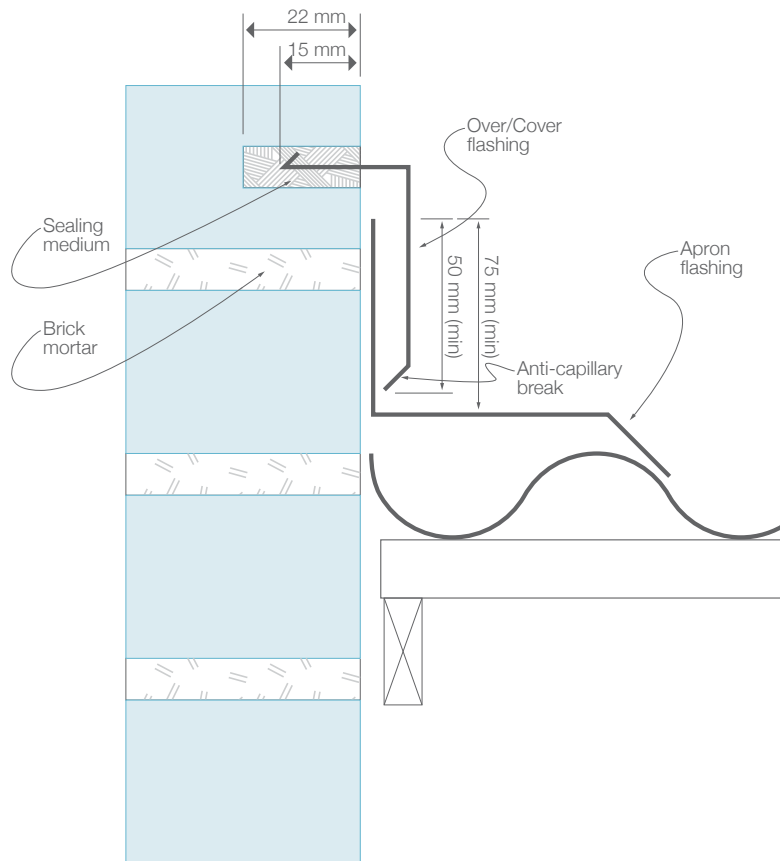
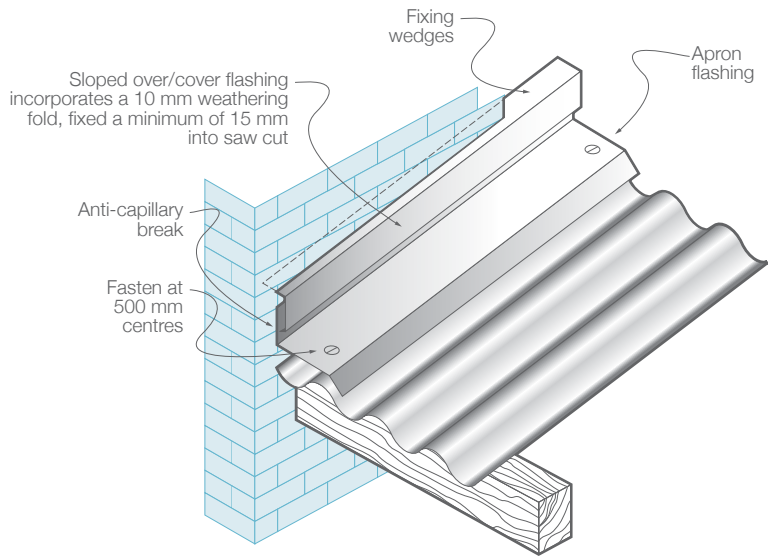

B Sloping wall cut method

DIAGRAM 7.06 FLASHINGS

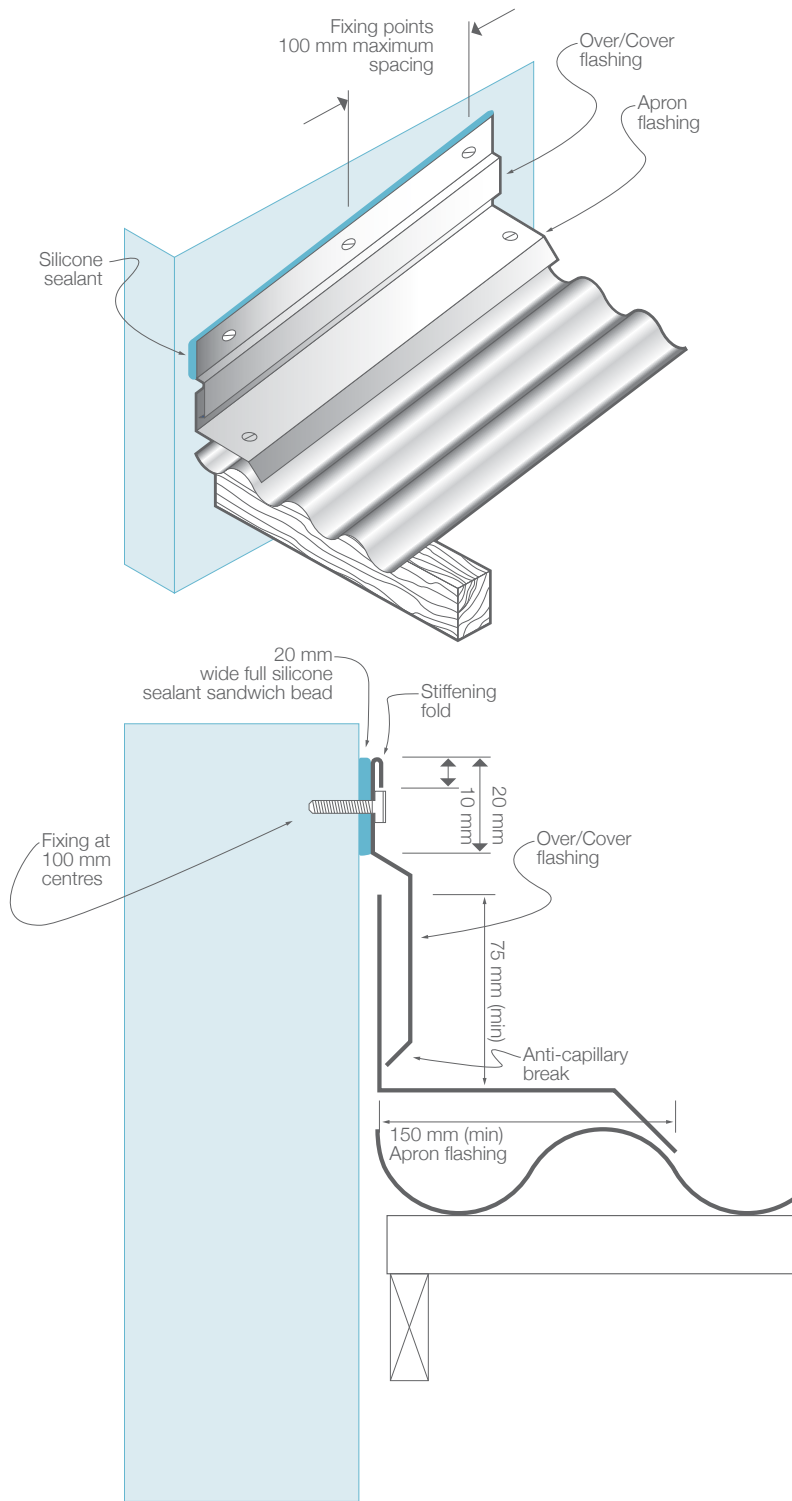

C Pressure flashing

7.07 Water hammer

Water hammer is defective if it is caused by the builder's workmanship.

7.08 Pipe penetrations through external walls and inside cupboards

Plumbing holes are defective if they are not:

- a) properly grouted as appropriate
- b) fitted through neat minimal size penetrations (in the case of cabinetwork)
- c) fitted with tight fitting cover plates or collars with penetrations kept to the smallest size practicable.

7.09 Water supply fixtures

Water supply fixtures are defective if they are not located to discharge clearly into the vessels such as baths, basins, sinks, troughs or the like.

7.10 Water drainage from baths, basins, sinks, troughs or the like

Baths, basins, sinks, troughs or the like are defective if they retain a pool of water after they have drained, with the exception of water retention due to surface tension.

7.11 Parapet flashings/cappings

Parapet flashings/cappings are defective if a minimum fall of three degrees is not provided across the width of the flashing to divert water runoff from dripping down the fascia and causing unsightly staining.

8 WINDOWS AND DOORS

8.01 Installation of external windows and doors

Unless documented otherwise, external windows and doors are defective if they are not installed and flashed in accordance with the manufacturer's installation instructions.

8.02 Weather-tightness of windows, doors, and window and door frames

Window frame and door frame installations are defective if, due to the builder's workmanship, they leak or cause unhealthy or dangerous conditions, loss of amenity for occupants, undue dampness or deterioration of building elements.

Windows and doors are defective if, when closed, they allow the entry of water.

Water entry through doors is not defective if they are not intended to prevent water entry. For example, vehicle access doors.

Windows and doors are defective if they are not sealed in accordance with the requirements of the Building Code of Australia, where required.

8.03 Door furniture

During the documented maintenance period after completion, handles, locks and latches are defective if they do not operate as intended by the manufacturer. If the maintenance period is not documented, three months is the assumed time period after completion. After the end of the maintenance period, failure is not a defect unless it is caused by the builder's workmanship or a faulty product supplied by the builder.

8.04 Internal door clearances

Unless documented otherwise, the installation of doors is defective if, within three months of completion:

- a) clearances between door leaves and frames, and between adjacent door leaves are not uniform
- b) clearances between door leaves, or between a door leaf and the frame, is less than 2 mm or greater than 5 mm in width.

Unless additional clearance is required for removable toilet doors or air ventilation, a clearance between the door and the floor finish is defective if it is greater than 20 mm after installation of the floor covering.

Note: Clearances under doors will generally be determined by the nominated floor coverings.

8.05 Distortion of doors

Door leaves are defective if, within three months of completion, they twist or bend greater than the limits listed in Table 8.05.

TABLE 8.05 DISTORTION OF DOORS

Item	Limit
Twisting measured diagonally across door	5 mm
Bending in door heights up to 2150 mm high	4 mm
Bending in door heights between 2150 and 2400 mm high	6 mm
Bending in door heights over 2400 mm high	7 mm
Bending in door widths up to 1020 mm wide	2 mm
Surface (face) misalignment, at the meeting edges of double swing or French doors, when the doors are fully closed	5 mm

8.06 Sealing of door edges

Door leaves are defective if they do not have all sides, top and bottom edges sealed/painted in accordance with the manufacturer's specifications.

8.07 Operation of windows and doors

The installation of doors and windows is defective if, within three months of completion, they:

- a) bind or jam as a result of the builder's workmanship
- b) do not operate as intended by the manufacturer.

8.08 Bowed window heads, sills and jambs

Windows frames are defective if they are distorted to the extent that the function of the window is adversely affected.

Refer also to Item 3.19 – Brick sills, sill tiles and shrinkage allowance for timber framing.

9 PLASTERING AND RENDERING

Explanatory Note 9A:

When assessing cracks in Item 9 of this Guide, Explanatory Note 2A at the start of Item 2 should be taken into consideration.

Vertical, plumbness and straightness of internal and external wall surfaces

9.01 Verticality or plumbness of internal and external wall surfaces

Wall surfaces are defective if they deviate from vertical by more than 5 mm over a 1.8 m straight edge. Refer to Diagram E on page 13 of this Guide.

9.02 Straightness of internal and external wall surfaces

Walls are defective if they deviate from plane (bow) by more than 5 mm over a 1.8 m straight edge. This tolerance includes internal walls with a build-up of plaster at internal and external corners of the plasterwork. Refer to Diagram E on page 13 of this Guide.

Rendered surfaces

Explanatory Note 9B:

Where an alternative wall cladding to Part 3.5.3 of the Building Code of Australia (BCA) is used, it must be an approved performance-based alternative solution or be a tested and accredited system in accordance with the requirements of the BCA and/or the Regulations.

The installation of the alternative wall cladding must be installed in accordance with the approved and tested system, including the specific proprietary products and accessories, components and installation methods specified in the approved system.

9.03 Matching and repairing existing rendered surfaces

The builder must try to match existing work.

In some instances this may not be possible as the original finish may have significantly aged or the material composition may be impossible to determine without expensive research.

When matching an existing finish, a practical approach must be adopted, and where possible a physical joint, door, window, downpipe or other similar separator should be incorporated to lessen the visual impact of the new work. Where this is not possible, the whole of that wall from corner to corner should be re-finished.

Where appropriate, defective work such as cracking should be monitored for 12 months or any other agreed period before determining what, if any, remedial work is required.

9.04 Cracking and other blemishes in rendered or hard plastered surfaces on a masonry substrate

Assess damage categories and defects in rendered or hard plastered surfaces on a masonry substrate, in accordance with Item 3.02.

Obvious spot rust marks, due to the composition of the material and other blemishes are defective if they are visible from a normal viewing position.

9.05 Repairs to applied finishes

Repairs to surfaces that have been rendered are defective if they do not match the colour and texture of the remaining wall or adjacent area as close as practicable.

9.06 Movement; Control joints – provision and cracking

Unless documented otherwise, cracks in rendered surfaces as determined in accordance with Item 3.02 of this Guide are defective if recommended movement control joints have not been installed.

9.07 Covering movement control joints and damp-proof courses

Mouldings and inflexible covering strips are defective if they are installed across movement control joints and are fixed or restrained on both sides.

Applied finishes are defective if they impede the performance of any damp-proof course or sub-floor ventilation required in accordance with the Building Code of Australia.

With the exception of paint and recommended mastic sealants, render or other applied finishes are defective if they cover movement control joints.

Unless documented otherwise, flexible mastic or sealant is defective if it does not match as close as practicable the colour of the adjacent surface and has not been used in accordance with the manufacturer's installation instructions.

9.08 Cracking in applied finishes used over lightweight substrate

Cracks or open joints in finishes applied to lightweight substrate are defective if they exist at handover or exceed 1 mm in width within the first 24 months and can be seen from a normal viewing position².

Cracks or open joints in finishes applied to lightweight sheet substrate are defective if they allow the ingress of water.

9.09 Rendered surfaces

Rendered or hard plastered surfaces are defective if they do not conform to the documented surface, sample or description.

2 Where diagonal cracking occurs, the underlying cause should be considered.

9.10 Cracking in external mouldings

Cracks in mouldings and/or other architectural features, including joints between those features and adjacent surfaces, are defective if they exist at handover or exceed 2 mm in width within the first 24 months and can be seen from a normal viewing position.

Internal plastering

9.11 Plasterboard sheeting

The installation and jointing of plasterboard sheeting systems is defective if it does not conform to AS/NZS 2589 and the manufacturer's installation instructions.

9.12 Other sheeting systems

Defects in the installation of other sheeting systems, such as fibre cement sheeting, shall be assessed in the same manner as plasterboard sheeting.

9.13 Level of finish for plasterboard

Unless documented otherwise, a plasterboard finish is defective if Level 4 finish (as defined below) is not provided.

Level 4 finish³

A Level 4 finish shall be the default level for gypsum lining, unless specified otherwise.

Flat or low sheen paints shall be used for this Level 4.

All joints and interior angles shall have tape embedded in jointing cement/jointing compound and a minimum of two separate coats of jointing cement/jointing compound applied over all joints, angles, fastener heads and accessories.

All jointing compound shall be finished evenly and be free of tool marks and ridges in preparation for decoration.

Notes:

1. In critical lighting conditions, surface imperfections may still be apparent in a Level 4 surface finish.
2. Where gloss, semi-gloss and deep tone paints are used, surface imperfections will be more evident.

9.14 Cracking in plasterboard, hard plaster and other plaster elements

Cracking in walls, ceilings and bulkheads is defective if it exists at handover or exceeds 1 mm in width within the first 24 months of completion and can be seen from a normal viewing position.

Cracking in recessed and butt joints is defective if it exists at handover or exceeds 1 mm in width within the first 24 months of completion and can be seen from a normal viewing position.

³ [AS/NZS 2589 Gypsum linings – Application and Finishing – Clause 3.1.4 – Level 4] – Reproduced with permission from SAI Global Ltd under Licence 1407-c122

9.15 Cracking in cornices

Cracking of cornice joints such as butt joints and mitres, and at junctions with walls and ceilings, is defective if it exists at handover or exceeds 1 mm in width within the first 24 months of completion and can be seen from a normal viewing position.

9.16 Cracking at junctions of dissimilar materials

Cracking at junctions between dissimilar materials is defective if it exists at handover or exceeds 1 mm in width within the first 12 months of completion and can be seen from a normal viewing position.

After the first 12 months, cracking that exceeds 2 mm is considered defective⁴.

9.17 Straightness and alignment of plaster cornices

Plaster cornices are defective if they deviate from a straight line greater than 4 mm over a length of up to 2 m and are visible from a normal viewing position.

9.18 Peaking or jointing in plasterboard

Plaster peaking or jointing is defective if it is visible from a normal viewing position⁵.

Nail popping

9.19 Nail popping in surfaces

Nail popping in sheeting is defective if it exists at handover or occurs within the first 24 months of completion and can be seen from a normal viewing position.

4 Consider installing movement control joints or mouldings in these locations.

5 CSIRO Report No L8 and TR90/1 *Illumination and decoration of flat surfaces* should also be consulted.

10 INTERNAL FIXING

10.01 Gaps associated with internal fixing

Unless documented otherwise, gaps between mouldings or between mouldings and other fixtures, at mitre or butt joints, or at junctions with a wall or other surfaces, are defective if they exist at handover, or exceed 1 mm in width within the first 12 months of completion and are visible from a normal viewing position.

After the first 12 months, gaps are defective if they exceed 2 mm in width and are visible from a normal viewing position.

Gaps between skirting and flooring are defective if they exceed 2 mm within the first 24 months after handover and are visible from a normal viewing position.

10.02 Joints in fixing of internal mouldings

Unless documented otherwise, the faces of architraves and skirtings are defective if they are not aligned and flush at mitres and butt joints and the misalignment can be seen from a normal viewing position.

10.03 Architrave quirks

The width of the quirk (setback from the edge) of each length of an architrave is defective if it is not consistent and where the irregularity can be seen from a normal viewing position.

10.04 Bench tops, cabinet doors and drawer fronts⁶

Unless otherwise specified, cabinet door and drawer fronts are defective if they are not aligned, or do not have consistent gaps between them at handover, and can be seen from a normal viewing position.

Where the time limit for defects in bench tops, cabinet doors, drawer fronts and similar joinery is not documented, it is to be taken as six months from completion.

10.05 Natural materials

Materials such as timber, granite and marble are natural products that may have blemishes and variations in pattern and colour that are natural characteristics of the material.

Stone materials are often brittle and may be easily cracked. Polished stone surfaces can be porous and subject to staining.

Any cracking, displacement, pitting or similar blemishes in natural stone, marble or similar materials are defective if they are caused by the builder and can be seen from a normal viewing position.

6 Refer also to AS/NZS 4386.1 *Domestic kitchen assemblies – Kitchen units*

10.06 Manufactured material

Any cracking, displacement, pitting or similar blemishes in surfaces of manufactured materials are defective if they are caused by the builder and can be seen from a normal viewing position.

Manufactured materials are defective if they are not installed in accordance with the manufacturer's requirements.

10.07 Rectification of defective natural materials and manufactured materials

The rectification of surfaces is defective if the rectification work does not reasonably match the adjacent areas. If reasonable matching is not possible, the entire surface shall be replaced⁷.

10.08 Joints in timber, stone and laminated bench tops

Bench tops of timber, laminate, natural stone or similar materials are defective if within six months of handover they have joints that are not uniform, close-fitted, aligned and in the same plane.

These requirements also apply to vertical surfaces of similar material and finish.

Joints are defective if they are not sealed or flush-filled with a suitable flexible sealant of matching colour at the time of handover.

10.09 Sealing around benches and items installed in benches

Where required, junctions between bench tops and adjoining surfaces are defective if they are not sealed with a suitable flexible sealant of matching or agreed colour.

Seals around items such as sinks, hand basins or the like are defective if the joint leaks or they are not installed in accordance with the manufacturer's installation requirements.

⁷ In these circumstances it is not normally necessary to replace areas of the material that are not adjacent to and contiguous with the affected area.

11 FLOOR AND WALL TILING

11.01 Floor and wall tiling

Unless documented otherwise, tiling work and materials are defective if they do not comply with AS 3958.1 and AS 3958.2 or the manufacturer's installation instructions for the materials selected.

The builder is responsible for tiling that fails because of defective building work in framing or slab construction, including tiling not laid by the builder.

Where the builder has to match tiles that are no longer available, a practical approach must be adopted. The use of a slightly different tile is not defective if it is used with the written agreement of the owner.

Where non-matching tiles have to be used, a joint location such as the aluminium channel of a shower screen, a separating doorway, an intersecting wall, a change in wall direction or similar should be selected to separate the different tiles.

11.02 Floor and wall tiling where the builder supplies the tiles

Where the supply and laying of tiles is by the builder, the failure of the tiles, substrate, adhesive or grout is defective.

11.03 Floor and wall tiling where the owner supplies the tiles for laying by the builder

Faulty installation of tiles is defective if caused by the builder's workmanship.

Any fault in the tiles is the responsibility of the owner, except where faults in the tiles should have been apparent to the builder at the time of laying, and these faults were not brought to the owner's attention.

11.04 Floor and wall tiles where the owner supplies and lays the tiles

The owner is responsible for checking the adequacy of the substrate before laying the tiles. Any failure of tiles, adhesive or grout, where the owner supplies and lays the tiles, is the responsibility of the owner.

11.05 Cracked, pitted, chipped, scratched or loose tiles

Tiles are defective if they are cracked, pitted, chipped, scratched or loose at handover.

After handover, tiles are defective where the builder's workmanship causes the tiles to become cracked, pitted, chipped or loose within 24 months.

11.06 Grouting and joints

Grouting is defective if it is not carried out in accordance with the requirements of Clause 5.7 of AS 3958.1.

Joints are defective if they are not, as far as is practicable, of consistent width and can be seen from a normal viewing position.

Finished grout is defective if it is not uniform in colour, smooth, without voids, pinholes or low spots.

- a) The top surface of the grout may be tooled to provide a contoured depression of no deeper than 1 mm for up to 6 mm wide joint and up to 2 mm for a 6-10 mm wide joint (clause 5.7(e) of AS 3958.1).
- b) Joint widths for floor tiles should not exceed 3 mm for pressed tiles and 6 mm for extruded tiles (clause 4.6(c)(i) of AS 3958.1).
- c) Joint widths for wall tiles should not exceed 1.5 mm for pressed tiles and 6 mm for extruded tiles (clause 5.4.6(c)(ii) of AS 3958.1).
- d) Joint alignment should be consistent throughout the installation within a tolerance of 4 mm in 2 m² (clause 5.4.6(d) of AS 3958.1).

Grout is defective if it becomes loose within 24 months of handover.

11.07 Flexible sealants to junctions

Flexible or waterproof sealants to junctions are defective if they are not installed when required by the Building Code of Australia and AS 3958.1, or in accordance with the manufacturer's installation requirements.

11.08 Uneven tiling

Except where tiles have distortions inherent in the manufacture, tiling is defective if it has joints that are not uniform, of even width, aligned or in the same plane.

Large tiles could present problems when required to fall and drain to a floor outlet.

8 This requirement does not apply to an interface between vertical and horizontal tiled surfaces.

11.09 Lippage (stepping) between tiles

Lippage is inherent in all installation methods and may also be unavoidable due to the tile tolerances. Lippage may also be unavoidable where tiles larger than 150 mm × 150 mm are graded to a waste outlet, unless transverse cuts are incorporated.

When measured with a straightedge, tiling is defective if the finished surface of the tiling is not flat and true to within a tolerance of ± 4 mm in 2m from the required plane.

Tiling is defective if the lippage between two adjacent tiles exceeds 2 mm. In the case of tiles where the surface has been ground flat, for example polished tiles, tiling is defective if the lippage exceeds 1.5 mm; for joint widths of 3 mm or less the lippage should not exceed 1 mm.

11.10 Movement joints

Tiled floors are defective if intermediate movement joints are not inserted at evenly spaced positions at approximately 4.5 m centres or at locations where stress might reasonably be expected in:

- a) internal floors where any dimension exceeds 9 m or 6 m if subjected to sunlight (clause 5.4.5.2(b)(i) of AS 3958.1)
- b) external floors where any dimension exceeds 4.5 m (clause 5.4.5.2(b)(ii) of AS 3958.1).

12 PAINTING

12.01 Standard of painting

Coatings used are to be suitable for the relevant conditions and relevant wear and tear.

Painting is defective if it does not comply with the manufacturer's installation instructions or AS/NZS 2311.

12.02 Surface finish of paintwork

Paintwork is defective if the application has blemishes such as paint runs, paint sags, wrinkling, dust, bare or starved painted areas, colour variations, surface cracks, irregular and coarse brush marks, sanding marks, blistering, non-uniformity of gloss level and other irregularities in the surface that are visible from a normal viewing position.

Paintwork is defective if the application results in excessive over-painting of fittings, trims, skirtings, architraves, glazing and other finished edges.

12.03 Nail and screw fixings

Fixings or unfilled depressions caused by fixings are defective in painted or stained surfaces if they can be seen from a normal viewing position.

12.04 Natural characteristics and mechanical imperfections/damage

Unless the contract specifies otherwise, natural characteristics such as gum pockets, surface splits or sap bleeding are defective if they can be seen from a normal viewing position.

Mechanical imperfections/damage, holes or any other unfilled depressions are defective if they can be seen from a normal viewing position.

12.05 Paint durability

Unless documented otherwise, coatings are defective if they fail by lifting, blistering, flaking, fading etc., within the minimum period shown in Table 12.05.

TABLE 12.05 MINIMUM DURABILITY OF COATED FINISHES

Coating	Minimum durability
Exterior acrylic	36 months
Exterior enamel	24 months
Exterior semitransparent stains	12 months
Exterior clear finishes	not recommended
Interior – all finishes	36 months

13 WET AREAS, DECKS AND BALCONIES

13.01 General

Flashings are defective if they are not installed in accordance with the requirements of the Building Code of Australia.

Shower recesses, decks and balconies mainly fail because of poorly installed waterproofing membranes and incorrect detailing. The greatest care should be taken to ensure the horizontal surface falls, flashing up-stands, vertical joints and drainage systems are installed exactly as specified for the particular system.

Internal wet areas

13.02 Wet areas

Waterproofing of wet areas is defective if not installed in accordance with the requirements of the Building Code of Australia and AS 3740.

13.03 Shower recess and components

Shower recess and components are defective if they crack, leak or don't perform as intended.

Scratches in shower bases, screens and glass are defective if they are due to the builder's workmanship and are visible from a normal viewing position.

All cracks in shower bases, screens and glass are defective if they exist at handover or are due to the builder's workmanship.

A shower component is defective if it allows the shower recess to leak during normal usage. Unenclosed shower screens are not intended to prevent the spread of water from the shower enclosure and are not considered defective.

Silicone sealants may require replacement after five years. This is regarded as normal house maintenance which is the owner's responsibility.

Beading of water on surfaces such as poly-marble shower bases and polished porcelain tiles is considered normal and is therefore not regarded as a defect.

External decks and balconies

Explanatory Note 13A:

Where a waterproof deck or balcony has been approved for construction before 1 May 2013 (date the Building Code of Australia adopted AS 4654.2), it should be completely installed in accordance with the approved system, including the specific proprietary products and accessories, components and installation methods specified in the approved system.

13.04 Leaks in waterproof decks and balconies

Waterproof decks and balconies that leak are defective.

13.05 Waterproof decks and balconies substrate

Waterproof decks and balconies are defective if they are not constructed in accordance with the Building Code of Australia and AS 4654.2.

Waterproof decks and balconies are defective if the waterproofing system is not installed in accordance with the manufacturer's installation requirements.

13.06 Decks and balcony freeboard outside windows and doors

Waterproof decks and balconies are defective if they do not have a drainage system sufficient to withstand wind-driven water surging from the deck or balcony that complies with the Building Code of Australia and AS 4654.2. See Diagram 13.06.

DIAGRAM 13.06 UPSTAND REQUIRED TO DOORWAYS OPENING ONTO EXTERNAL DECKS

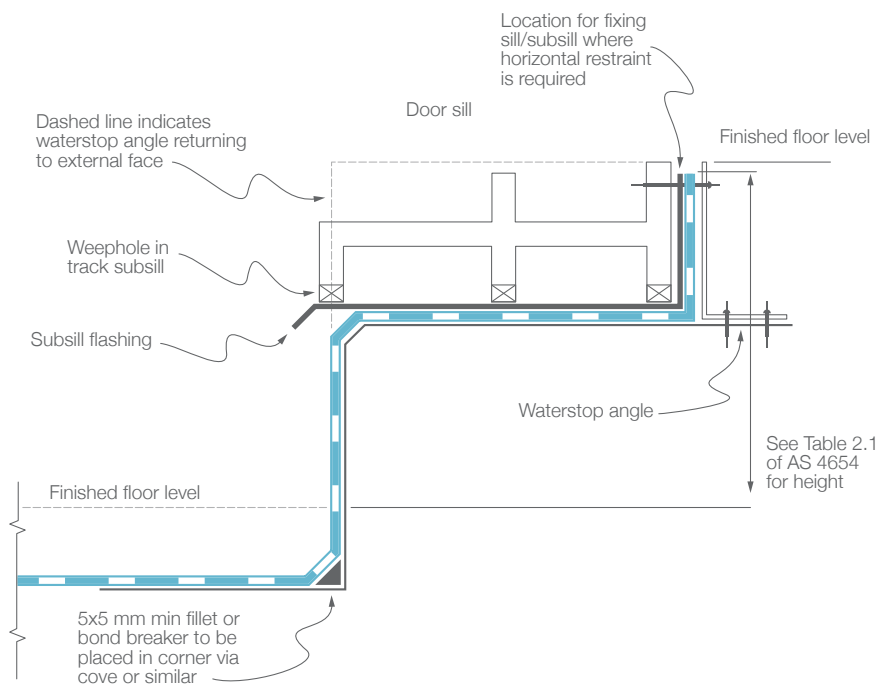

13.07 Ponding on waterproof decks and balconies

Waterproof decks and balconies are defective if water ponds (with the exception of residual water remaining due to surface tension) or does not drain to the outer edge⁹ or a stormwater inlet.

Decks and balconies that are required to be waterproofed are defective if they are not provided with adequate drainage and provision for overflow.

13.08 Calcification and efflorescence associated with decks and balconies

Calcification or efflorescence caused by water coming from a deck or balcony that occurs on walls below or beside the deck or balcony, or that appears in the mortar joints of the deck or balcony tiling, is defective. Activities of others, such as owners watering plants, may also contribute to the efflorescence, which may not be attributed to the work of the builder.

⁹ Item 13.08 of this Guide should be considered when draining water to vertical surfaces (ie. walls).

14 FLOORS

14.01 Timber flooring – shrinkage and swelling

Timber flooring will shrink or swell according to its internal moisture content, timber species used and the installation environment. The internal moisture content will adjust to the surrounding atmosphere after the timber is installed and this may lead to permanent or seasonal swelling, splitting or shrinkage creating gaps at board edges.

Exposure to sunlight, cooling, heating or other heat generating appliances is likely to cause localised shrinkage of timber that cannot be allowed for at the time of construction. This is to be taken into consideration when determining if there is defective workmanship.

When assessing the appearance of a floor it is to be done from a normal viewing position.

14.02 Timber flooring

Flooring, including tongue and groove strip flooring; structural plywood and particleboard sheet flooring, is defective if it is not installed according to AS 1684 and the manufacturer's installation requirements.

Colour variations due to natural causes such as sunlight are not defective.

Ghosting, where blemishes appear beneath the finish coat, is defective when visible from a normal viewing position.

Due to necessary machining tolerances a step (lippage) of up to 0.5 mm or slight movement may exist between adjacent floor boards. This step (lippage) should not be evident at handover if the floorboards are also sanded and polished by the builder.

14.03 Gaps in exposed timber flooring

Except where affected by exposure to sunlight, cooling, heating or other heat generating appliances, flooring is defective if it has gaps of more than 2 mm between adjacent boards that extend for more than 1 m, or more than 5 mm in total of three gaps between four consecutive boards¹⁰.

14.04 Joint swelling in timber, plywood and particleboard flooring

Joints in plywood and particleboard floors are defective if they can be detected through normal floor coverings.

Swelling in tongue and groove strip timber flooring is defective if it causes tenting, buckling or crowning of the boards and can be seen from a normal viewing position.

Cupping in boards of more than 1 mm per 100 mm is a defect (Table C3 of AS 2796.1).

¹⁰ Flooring with gaps that exceed the allowances stated above is not defective when the builder in writing has made the owners aware that the flooring system installed could suffer significant shrinkage and has obtained this acknowledgement in writing.

14.05 Nail popping in timber, plywood and particleboard floors¹¹

Nail heads that can be detected through floor coverings or nail popping that is clearly visible in exposed flooring are defective if they occur within 24 months from handover.

14.06 Squeaking floors

Floors that consistently squeak by a person walking normally in a trafficable area within the first 24 months from handover are defective.

14.07 Springy floors

Floors that bounce in a way that can be detected by a person walking normally in a trafficable area are defective if the substructure has not been constructed in accordance with the Building Code of Australia and AS 1684.

14.08 Levelness of timber floor

New floors are defective if within the first 24 months of handover they differ in level by more than 10 mm in any room or area, or more than 4 mm in any 2 m length.

The overall deviation of floor level to the entire building footprint shall not exceed 20 mm within 24 months of handover. Refer to Item I of this Guide where the new floor is to adjoin an existing floor.

14.09 Splitting of timber decking

Splits in timber decking that extend to the end or side edge of the timber is defective if they are due to the fixing method.

¹¹ Owners who undertake their own floor polishing of exposed flooring or who lay floor coverings after completion of the builder's works are responsible to ensure that all nails and other fixings are properly punched or countersunk and stopped.

15 ELECTRICAL**15.01 Electrical**

Any electrical work is defective if it does not comply with the relevant regulations or the contract documents.

The builder shall provide the owner with a Certificate of Electrical Safety when a certificate is required to be issued by the licenced electrician.

16 POOLS AND SPAS

16.01 Concrete pools and spas

Concrete pools and spas are defective if they do not comply with AS 2783.

16.02 Premoulded fibre-reinforced plastic pools and spas

Premoulded pools and spas are defective if they are not installed in accordance with AS/NZS 1839.

16.03 Variations from documented dimensions in concrete pools and spas

Departures from the documented set out for concrete pools and spas are defective if they exceed $L/100$, where L is the documented dimension, or 5 mm, whichever is the greater.

16.04 Variations from documented datum in concrete pools and spas

Set outs that depart from documented reduced levels or finished floor levels by more than 40 mm are defective.

17 RESTUMPING

17.01 Restumping

Owners should understand the limitations imposed on re-levelling of existing structures by such factors as:

- a) existing structural conditions
- b) fixed points
- c) attached buildings
- d) extensions to the dwelling
- e) plumbing installations
- f) likelihood of consequential damage to wall claddings
- g) any other factor that may restrict the re-levelling process.

17.02 Consequential damage due to restumping

Consequential damage caused by restumping works is not defective where the builder has documented evidence that the owner has been informed of the nature and likelihood of such damage.

In the absence of documented evidence that the owner has been informed of the nature and likelihood of damage associated with restumping; consequential damage caused by restumping work may be considered defective.

17.03 Floor levels after restumping

Except where documented otherwise, re-levelled floors are defective if within the first 24 months, they differ in level by more than 15 mm in any room or area, or more than 8 mm in any 2 m length.

18 GENERAL

18.01 Appliances and fittings

The owner is responsible for organising warranty service for faults in appliances and fittings supplied as part of the building contract where the builder has provided the warranty documents to the owner. Service outside the warranty period is the responsibility of the owner.

18.02 Faults and damage to appliances and fittings

Damage to appliances and fittings supplied as part of the building contract is defective if it is due to the builder's workmanship.

During the documented maintenance period after handover, fittings are defective if they do not operate as intended by the manufacturer. If the maintenance period is not documented it is to be taken as three months.

18.03 Condensation

Condensation is a common problem in buildings (particularly in bathrooms and laundries) and can occur on windows, under unlined roofs or elsewhere. Further information is available in the Australian Building Codes Board Handbook – *Condensation in Buildings (2014)*.

Where the requirements of the Building Code of Australia (BCA) have been complied with, the responsibility for controlling condensation by maintaining adequate natural or mechanical ventilation through the use of openable windows, exhaust fans, or other means, is the responsibility of the owner.

Condensation is defective if the builder has not complied with the relevant clauses of the BCA.

18.04 Glazing

Scratches, fractures, chips or surface blemishes on glazing and mirrors are defective if they exist at handover and can be seen from a normal viewing position.

Minor scratches, fractures, chips or other blemishes that are not more than 10 mm long and where there are not more than three blemishes per pane, are not defects.

18.05 Lyctus borer

Timber is defective if it is used during construction with evidence of lyctus borer attack, unless the timber product has been approved by the manufacturer.

18.06 Termites

Termites are a widespread problem in all areas of Australia and it is the owner's responsibility to regularly inspect the property, including sub-floor inspections, to detect evidence of termite attack.

Termites can circumvent properly executed termite protection measures, such as building tunnels around barriers. Tunnels can be identified through regular inspections and, if found, the termite nest should be located and destroyed by a suitably qualified pest controller.

Termite management systems are intended to reduce the risk of damage to the structural members of buildings by deterring concealed entry of termites into a building. Termite management systems cannot prevent the entry of termites into the building. In Victoria, a termite management system is only required to be installed where the primary building elements are susceptible to termite attack, as defined in the Building Code of Australia.

18.07 Termite damage

Damage caused by termites that occurs in areas not designated by the relevant council as a termite risk area is the responsibility of the owner.

Damage caused by termites in buildings within designated termite risk areas is defective if the termite management system has not been installed in accordance with the Building Code of Australia.

Damage caused by termites in buildings within designated termite risk areas is not defective if the termite management system has not been regularly maintained by the owner, made non-compliant by the owner after handover, or not maintained in accordance with the manufacturer's instructions and AS 3660.2.

18.08 Cleaning

Owners are entitled to expect that the building site and works are clean and tidy on completion. Where handover is delayed for any reason the owner must expect that dust may have settled on interior exposed surfaces.

Building sites are defective if they are not clear of building debris.

Building works are defective where windows are not clean, floors are not swept, mopped or vacuumed as appropriate, tiles, sinks, basins, troughs, baths, etc. are not cleaned, and shelving, drawers and cupboards ready for use.

18.09 Maintenance in relation to the performance of building foundations/footings

Proper ongoing maintenance of the building is a normal part of homeownership and the homeowner is responsible for all maintenance after handover.

An important part of building maintenance is maintaining a consistent moisture level in the foundation soils around the building. This is important in order to prevent excessive wetting (expansion) or drying (shrinking) of the foundation soils and subsequent building movement.

Many things can adversely alter the moisture level in the foundation soils around the building, but most of them are preventable with careful ongoing maintenance. Diagram 18.09 lists common causes of excessive wetting and drying that are likely to alter moisture level in foundation soils around the building if not managed effectively.

DIAGRAMS 18.09 MAINTENANCE

Consideration of the items listed in Diagram 18.09 should all be a normal part of a homeowner's maintenance plan.

Homeowner's should refer to the CSIRO publications listed in Part M and the Explanatory Note in Section 2 of this Guide for additional information.

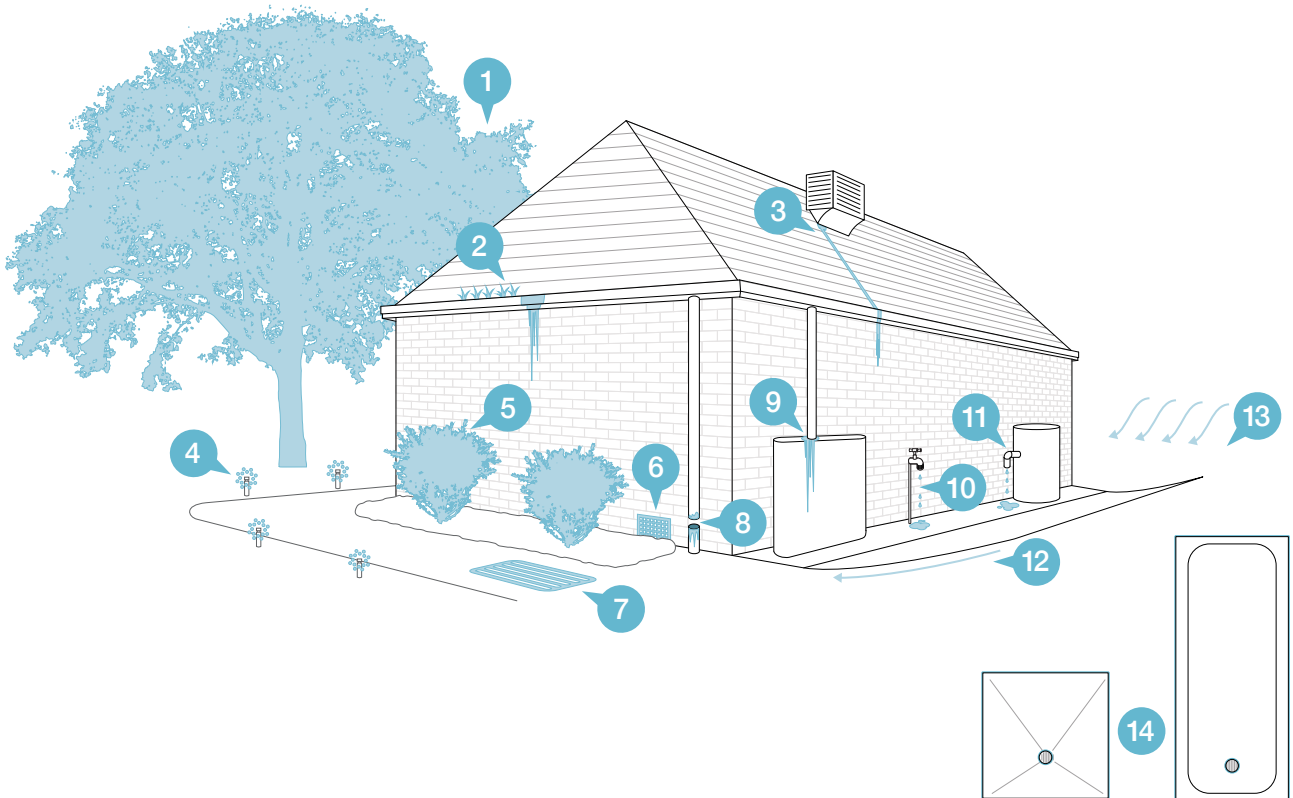

1. Trees planted too close to house (Refer to CSIRO document BTF18 *Foundation Maintenance and Footing Performance*).
2. Blocked gutters, eaves, valley and box gutters to house, enclosed roofs and decks.
3. Air-conditioner overflows: roof and ground.
4. Faulty, unmaintained or poorly placed sprinkler systems.
5. Garden beds and large shrubs placed too close to house.
6. Ground level above damp-proof courses, weepholes and subfloor vents.
7. Surface drainage pits, silt pits and underground stormwater drainage system not regularly cleaned out.
8. Damaged or unconnected stormwater downpipes.
9. Overflowing water tanks.
10. Dripping external taps.
11. Dripping water heater relief valves.
12. Paving, landscaping or ground surfaces slope towards building.
13. Water runoff from higher adjoining properties.
14. Resealing of wet area junctions: shower screens and bath hobs.

18.10 Floor coverings

Carpet and vinyl is defective if it is not installed in accordance with the manufacturer's installation recommendations.

Joins in carpet and vinyl are defective if they peak, fray or misalign and are visible from a normal viewing position within 12 months from handover.

Floating floors which rest on the structural floor are defective if not installed in accordance with the manufacturer's installation requirements. Movement noises are an inherent characteristic of this type of flooring.

Relevant legislation

These principal pieces of legislation are applicable to domestic building construction in Victoria:

- a) *Building Act 1993*
- b) *Domestic Building Contracts Act 1995*
- c) *Building Regulations 2006*
- d) *Plumbing Regulations 2008*

History of editions

This version of the *Guide to Standards and Tolerances* applies to building work and/or contracts for domestic building work entered into after 30 March 2015.

The *Guide to Standards and Tolerances* dated 2007 is applicable to all building work and/or contracts entered into from 1 January 2007 to 29 March 2015.

The *Guide to Standards and Tolerances* dated 2002 (July 2003 in NSW) is applicable to all contracts entered into from 1 July 2002 (July 2003 in NSW) to 31 December 2006.

The *Guide to Standards and Tolerances* dated 1 April 1999 is applicable to contracts entered into from this date to 30 June 2002.

The *Guide to Standards and Tolerances* dated 1 May 1996 is applicable to contracts entered into from this date to 31 March 1999.

The *Guide to Standards and Tolerances* dated December 1992 is applicable to contracts entered into from this date to 30 April 1996.

Previous editions of the *Guide to Standards and Tolerances* are available by contacting the Victorian Building Authority. Visit www.vba.vic.gov.au

Victorian Building Authority
Goods Shed North
733 Bourke Street, Docklands
Victoria, Australia 3008
GPO Box 536, Melbourne
Victoria, Australia 3001
P: 1300 815 127
F: 03 9618 9062
W: vba.vic.gov.au
DX 210 299 Melbourne

